



Spare Parts List
Ersatzteilliste
Liste de pièces détachées
Lista de piezas de repuesto

2005-04



UM332 2005 →
UM370 2005 →
UM430 2005 →
UM480 2005 →



EUM430 2005 →
EUM481 2005 →
EUM480 2005 →

995 700 625 (DE, GB, FR, ES)

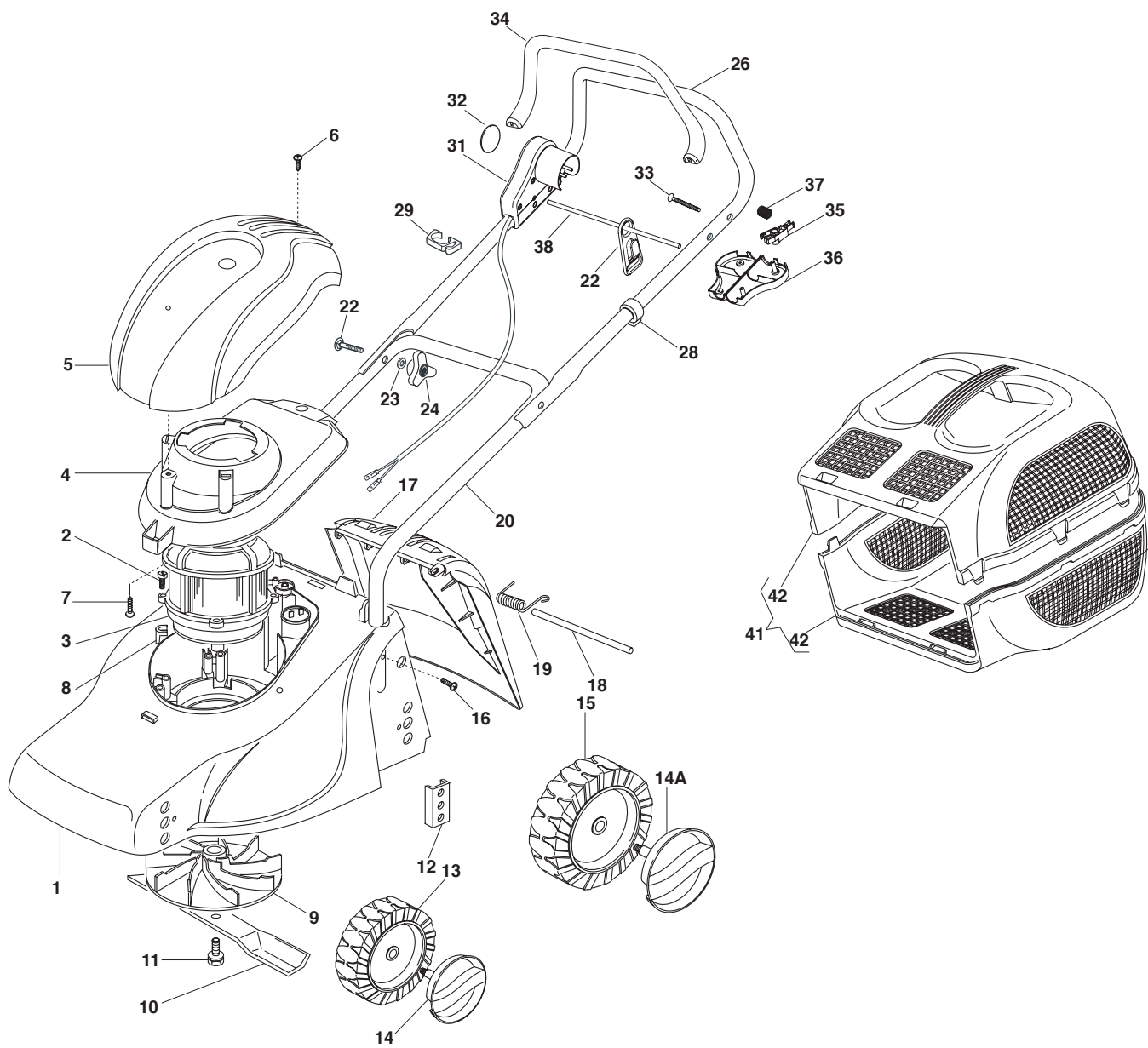



Seite / Page	Pos.	UM332	UM370	UM430	UM480	EUM430	EUM481	EUM480	Teil-Nr. Part No. No. de pièce No. de pieza	Bezeichnung	Spezifikation Specification	Description	Désignation	Denominación
1	1	1							664 002 366	GEHÄUSE ROT		DECK RED	CHÂSSIS ROUGE	CAJA ROJA
1	2	4							664 735 410	SCHRAUBE		SCREW	VIS	TORNILLO
1	3	1							664 563 632	MOTOR FEVILL ELECTRIC	230-240V	MOTOR FEVILL ELECTRIC	MOTEUR FEVILL ELECTRIC	MOTOR FEVILL ELÉCTRICO
1	4	1							664 055 050	HALTER, HAUBE		SUPPORT, COVER	SUPPORT CAPOT	SOPORTE, CUBIERTA
1	5	1							664 055 049	HAUBE		COVER	CAPOT	CUBIERTA
1	6	1							664 728 680	SCHRAUBE		SCREW	VIS	TORNILLO
1	7	1							664 728 450	SCHRAUBE		SCREW	VIS	TORNILLO
1	8	4							664 167 700	DISTANZRING		SPACER	ENTRETOISE	DISTANCIADOR
1	9	1							664 465 602	MESSERHALTER		HUB	MOYEU	SOPORTE DE LA CUCHILLA
1	10	1							664 004 115	MESSER	33 CM	BLADE	LAME	CUCHILLA ESTÁNDAR
1	11	1							664 004 352	MESSERSCHRAUBE		SCREW	VIS	TORNILLO
1	12	4							664 785 087	HÖHENVERSTELLUNG		SUPPORT, WHEELS	SUPPORT ROUE	SOPORTE, RUEDAS
1	13	2							664 686 083	RAD	Ø 130	WHEEL	ROUE	RUEDA
1	14	2							664 004 322	RADKAPPE ROT		HUB CAP RED	COUVRE-MOYEU ROUGE	TAPACUBOS ROJO
1	14,A	2							664 004 323	RADKAPPE ROT		HUB CAP RED	COUVRE-MOYEU ROUGE	TAPACUBOS ROJO
1	15	2							664 686 085	RAD	Ø 160	WHEEL	ROUE	RUEDA
1	16	2							664 728 450	SCHRAUBE		SCREW	VIS	TORNILLO
1	17	1							664 600 055	PRALLBLECH		STONE-GUARD	PARE-PIERRES	CUBIERTA PROTECTORA
1	18	1							664 512 530	BOLZEN		PIN	PIVOT	PIVOTE
1	19	1							664 450 250	FEDER		SPRING	RESSORT	RESORTE
1	20	1							664 006 608	HOLM, UNTERTEIL		HANDLE, LOWER PART	MANCHERON, PARTIE INFERIEURE	MANILLAR, PARTE INFERIOR
1	22	2							664 815 245	SCHRAUBE		SCREW	VIS	TORNILLO
1	23	2							664 523 040	SCHEIBE		WASHER	RONDELLE	ARANDELA
1	24	2							664 399 903	GRIFF		KNOB	POIGNÉE	MANETA
1	26	1							664 006 647	HOLM, OBERTEIL		HANDLE, UPPER PART	MANCHERON, PARTIE SUPERIEURE	MANILLAR, PARTE SUPERIOR
1	28	1							664 192 151	KABELBEFESTIGUNG		FAIRLEAD	FIXATION CABLE	SUJETACABLE
1	29	1							664 192 010	BOWDENZUGHALTER		ANCHOR CLAMP	COLLIER ANCRAGE	SOPORTE CABLE BOWDEN
1	30	1							664 195 101	KABELBEFESTIGUNG		FAIRLEAD	FIXATION CABLE	SUJETACABLE
1	31	1							664 600 503	TOTMANN-SCHALTER		DEAD HAND SWITCH	INT. MAIN MORTE	INTERRUPTOR DE HOMBRE MUERTO
1	32	1							664 034 601	SCHUTZ		PROTECTION	PROTECTION	PROTECCIÓN
1	33	4							664 728 685	SCHRAUBE		SCREW	VIS	TORNILLO
1	34	1							664 322 880	HEBEL, MOTORBREMSE		LEVER, MOTOR BRAKE	LEVIER FREIN MOTEUR	PALANCA, FRENO MOTOR
1	35	1							664 230 350	GELENKPUNKT		FULCRUM PIN	POINT D'APPUI	PUNTO DE ARTICULACIÓN
1	36	1							664 785 144	HALTER		SUPPORT	SUPPORT	SOPORTE
1	37	1							664 450 115	FEDER		SPRING	RESSORT	RESORTE
1	38	1							664 010 250	KABELHALTER		FAIRLEAD BEARING	SUPPORT SERRECABLE	SOPORTE SUJETACABLE
1	41	1							664 350 000	KORB, KOMPLETT		GRASSCATCHER, COMPLETE	SAC, COMPLETE	CESTO, COMPLETO
1	42	2							664 486 048	KORB, OBER/UNTERTEIL		GRASS-BOX, UPPER/LOWER PART	SAC, PARTIE INFERIEURE/SUPERIEURE	CESTO, PARTE SUPERIOR/INFERIOR

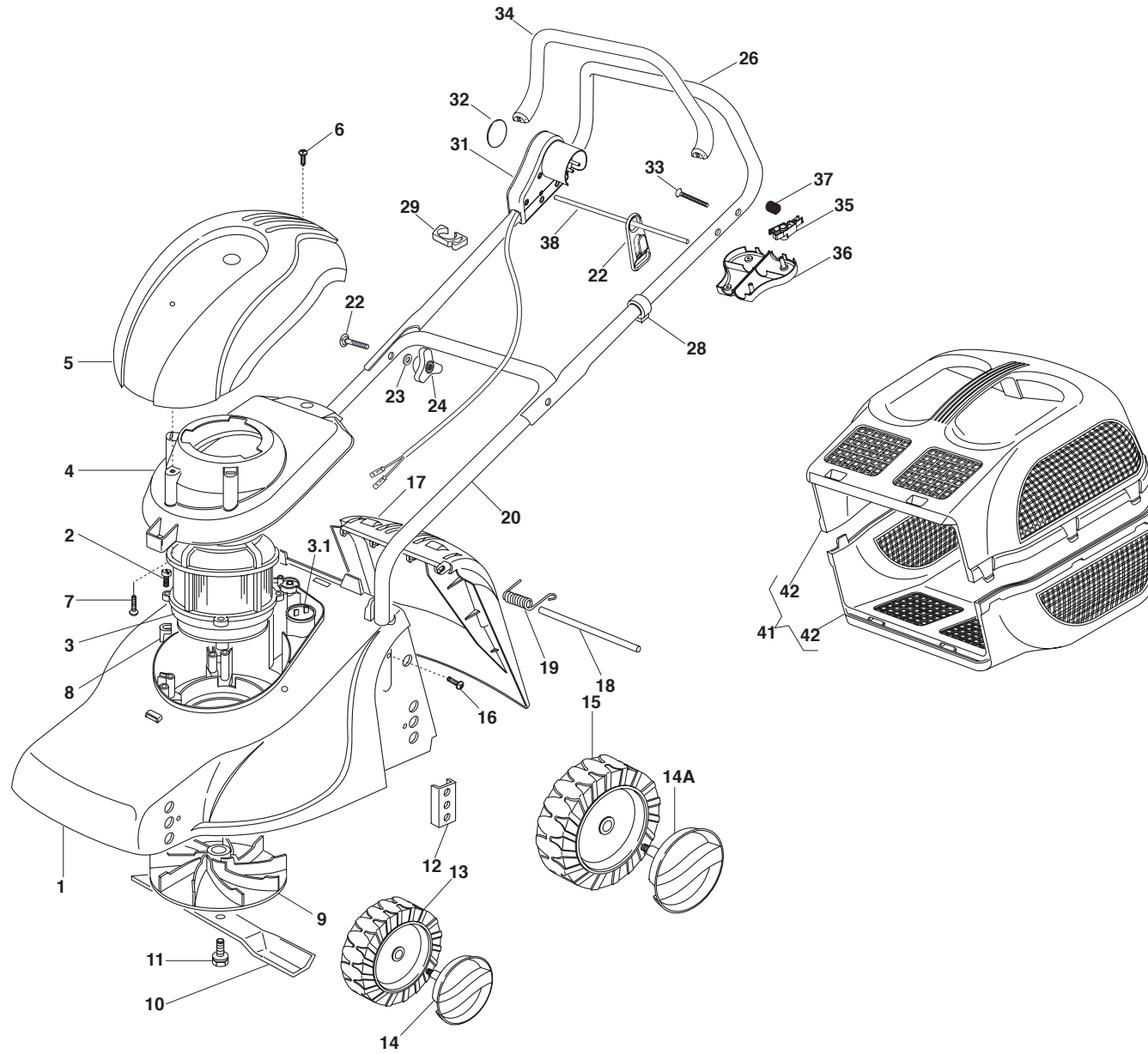



Seite / Page	Pos.	UM332	UM370	UM430	UM480	EUM430	EUM481	EUM480	Teil-Nr. Part No. No. de pièce No. de pieza	Bezeichnung	Spezifikation Specification	Description	Désignation	Denominación
2	1		1						664 002 367	GEHÄUSE ROT		DECK RED	CHÂSSIS ROUGE	CAJA ROJA
2	2		4						664 735 410	SCHRAUBE		SCREW	VIS	TORNILLO
2	3		1						664 563 633	MOTOR FEVILL ELECTRIC	230-240V	MOTOR FEVILL ELECTRIC	MOTEUR FEVILL ELECTRIC	MOTOR FEVILL ELÉCTRICO
2	3,1		1						664 222 038	KONDENSATOR	20 µF	CONDENSER	CONDENSEUR	CONDENSADOR
2	4		1						664 055 050	HALTER, HAUBE		SUPPORT, COVER	SUPPORT CAPOT	SOPORTE, CUBIERTA
2	5		1						664 055 049	HAUBE		COVER	CAPOT	CUBIERTA
2	6		1						664 728 680	SCHRAUBE		SCREW	VIS	TORNILLO
2	7		1						664 728 450	SCHRAUBE		SCREW	VIS	TORNILLO
2	8		4						664 167 700	DISTANZRING		SPACER	ENTRETOISE	DISTANCIADOR
2	9		1						664 465 602	MESSERHALTER		HUB	MOYEU	SOPORTE DE LA CUCHILLA
2	10		1						664 004 117	MESSER	37 CM	BLADE	LAME	CUCHILLA ESTÁNDAR
2	11		1						664 004 352	MESSERSCHRAUBE		SCREW	VIS	TORNILLO
2	12		4						664 785 087	HÖHENVERSTELLUNG		SUPPORT, WHEELS	SUPPORT ROUE	SOPORTE, RUEDAS
2	13		2						664 686 083	RAD	Ø 130	WHEEL	ROUE	RUEDA
2	14		2						664 004 322	RADKAPPE ROT		HUB CAP RED	COUVRE-MOYEU ROUGE	TAPACUBOS ROJO
2	14,A		2						664 004 323	RADKAPPE ROT		HUB CAP RED	COUVRE-MOYEU ROUGE	TAPACUBOS ROJO
2	15		2						664 686 085	RAD	Ø 160	WHEEL	ROUE	RUEDA
2	16		2						664 728 450	SCHRAUBE		SCREW	VIS	TORNILLO
2	17		1						664 600 056	PRALLBLECH		STONE-GUARD	PARE-PIERRES	CUBIERTA PROTECTORA
2	18		1						664 512 530	BOLZEN		PIN	PIVOT	PIVOTE
2	19		1						664 450 250	FEDER		SPRING	RESSORT	RESORTE
2	20		1						664 006 608	HOLM, UNTERTEIL		HANDLE, LOWER PART	MANCHERON, PARTIE INFERIEURE	MANILLAR, PARTE INFERIOR
2	22		2						664 815 245	SCHRAUBE		SCREW	VIS	TORNILLO
2	23		2						664 523 040	SCHEIBE		WASHER	RONDELLE	ARANDELA
2	24		2						664 399 903	GRIFF		KNOB	POIGNÉE	MANETA
2	26		1						664 006 647	HOLM, OBERTEIL		HANDLE, UPPER PART	MANCHERON, PARTIE SUPERIEURE	MANILLAR, PARTE SUPERIOR
2	28		1						664 192 151	KABELBEFESTIGUNG		FAIRLEAD	FIXATION CABLE	SUJETACABLE
2	29		1						664 192 010	BOWDENZUGHALTER		ANCHOR CLAMP	COLLIER ANCRAGE	SOPORTE CABLE BOWDEN
2	30		1						664 195 101	KABELBEFESTIGUNG		FAIRLEAD	FIXATION CABLE	SUJETACABLE
2	31		1						664 600 503	TOTMANN-SCHALTER		DEAD HAND SWITCH	INT. MAIN MORTE	INTERRUPTOR DE HOMBRE MUERTO
2	32		1						664 034 601	SCHUTZ		PROTECTION	PROTECTION	PROTECCIÓN
2	33		4						664 728 685	SCHRAUBE		SCREW	VIS	TORNILLO
2	34		1						664 322 880	HEBEL, MOTORBREMSE		LEVER, MOTOR BRAKE	LEVIER FREIN MOTEUR	PALANCA, FRENO MOTOR
2	35		1						664 230 350	GELENKPUNKT		FULCRUM PIN	POINT D'APPUI	PUNTO DE ARTICULACIÓN
2	36		1						664 785 144	HALTER		SUPPORT	SUPPORT	SOPORTE
2	37		1						664 450 115	FEDER		SPRING	RESSORT	RESORTE
2	38		1						664 010 250	KABELHALTER		FAIRLEAD BEARING	SUPPORT SERRECABLE	SOPORTE SUJETACABLE
2	41		1						664 390 000	KORB, KOMPLETT		GRASSCATCHER, COMPLETE	SAC, COMPLETE	CESTO, COMPLETO
2	42		2						664 486 049	KORB, OBER/UNTERTEIL		GRASS-BOX, UPPER/LOWER PART	SAC, PARTIE INFERIEURE/SUPERIEURE	CESTO, PARTE SUPERIOR/INFERIOR



Seite / Page	Pos.	UM332	UM370	UM430	UM480	UM481	UM480	Teil-Nr. Part No. No. de pièce No. de pieza	Bezeichnung	Spezifikation Specification	Description	Désignation	Denominación
3	1			1				664 002 363	GEHÄUSE ROT		DECK RED	CHÂSSIS ROUGE	CARCASA ROJA
3	2			2				664 293 200	6KT-MUTTER	M8	NUT	ECROU	TUERCA
3	3			2				664 399 900	GRIFF		KNOB	POIGNÉE	MANETA
3	4			1				664 034 601	SCHUTZ		PROTECTION	PROTECTION	PROTECCIÓN
3	5			4				664 728 685	SCHRAUBE		SCREW	VIS	TORNILLO
3	6			1				664 230 350	GELENKPUNKT		FULCRUM PIN	POINT D'APPUI	PUNTO DE ARTICULACIÓN
3	7			1				664 785 144	HALTER		SUPPORT	SUPPORT	SOPORTE
3	8			1				664 450 115	FEDER		SPRING	RESSORT	RESORTE
3	9			1				664 450 410	FEDER RECHTS		R SPRING	RESSORT D	RESORTE DER.
3	10			1				664 600 063	PRALLBLECH		STONE-GUARD	PARE-PIERRES	CUBIERTA PROTECTORA
3	11			1				664 450 420	FEDER LINKS		L SPRING	RESSORT G	RESORTE IZQ.
3	12			1				664 517 906	STANGE		PIN	PIVOT	PASADOR
3	14			1				664 322 881	HEBEL, MOTORBREMSE		LEVER, MOTOR BRAKE	LEVIER FREIN MOTEUR	PALANCA, FRENO MOTOR
3	15			2				664 680 006	SCHEIBE		WASHER	RONDELLE	ARANDELA
3	16			2				664 819 201	SCHRAUBE		SCREW	VIS	TORNILLO
3	17			3				664 192 000	BOWDENZUGHALTER		ANCHOR CLAMP	COLLIER ANCRAGE	GRAPA DE SUJECCIÓN
3	18			1				664 600 503	TOTMANN-SCHALTER		DEAD HAND SWITCH	INT. MAIN MORTE	INTERRUPTOR DE HOMBRE MUERTO
3	19			1				664 195 101	KABELBEFESTIGUNG		FAIRLEAD	FIXATION CABLE	SUJETACABLE
3	20			1				664 006 603	HOLM, OBERTEIL		HANDLE, UPPER PART	MANCHERON, PARTIE SUPERIEURE	MANILLAR, PARTE SUPERIOR
3	21,B			1				664 055 065	HAUBE		COVER	CAPOT	CUBIERTA
3	22			2				664 728 680	SCHRAUBE		SCREW	VIS	TORNILLO
3	23			1				664 806 518	HALTER, RECHTS		SUPPORT, R	SUPPORT D	SOPORTE, DER.
3	24			1				664 010 251	KABELHALTER		FAIRLEAD BEARING	SUPPORT SERRECABLE	SOPORTE SUJETACABLE
3	25			1				664 001 245	ANTRIEB HEBEL		DRIVING LEVER	LEVIER TRACTION	PALANCA DE LA PROPULSIÓN
3	26			1				664 806 519	HALTER, LINKS		SUPPORT, L	SUPPORT G	SOPORTE, IZQ.
3	27			3				664 680 006	SCHEIBE		WASHER	RONDELLE	ARANDELA
3	28			3				664 523 040	SCHEIBE		WASHER	RONDELLE	ARANDELA
3	29			3				664 735 103	SCHRAUBE		SCREW	VIS	TORNILLO
3	30			1				664 806 520	HALTER, REGLER		SUPPORT, ADJUSTER	SUPPORT ECROU REG.	SOPORTE, AJUSTE
3	31			2				664 545 152	LAGERSCHALE		PLATE	PLAQUETTE	COJINETE
3	32			4				664 731 350	SCHRAUBE		SCREW	VIS	TORNILLO
3	33			1				664 060 191	SCHUTZ, RIEMEN		PROTECTION, BELT	PROTECTION	PROTECCIÓN, CORREA
3	34			1				664 727 791	SCHRAUBE		SCREW	VIS	TORNILLO
3	35			1				664 000 930	SPRENGRING		SNAP RING	ANNEAU RESSORT	ANILLO DE SUJECCIÓN
3	51			1				664 006 532	HOLM, UNTERTEIL		HANDLE, LOWER PART	MANCHERON, PARTIE INFERIEURE	MANILLAR, PARTE INFERIOR
3	52			2				664 785 081	HALTER, AUßEN		SUPPORT, EXTERNAL	SUPPORT EXTERNE	SOPORTE, EXTERIOR
3	53			1				664 785 082	HALTER, INNEN R		SUPPORT, R INTERNAL	SUPPORT INTERNE D	SOPORTE INTERIOR, DER.
3	54			1				664 785 083	HALTER, INNEN L		SUPPORT, L INTERNAL	SUPPORT INTERNE G	SOPORTE INTERIOR, IZQ.
3	56			2				664 551 575	PLATTE, INNEN		PLATE, INSIDE	PLAQUETTE INTERNE	PLANCHA, INTERIOR
3	57			2				664 793 701	SCHRAUBE		SCREW	VIS	TORNILLO
3	58			2				664 155 000	MUTTER		NUT	ECROU	TUERCA



Seite / Page	Pos.	UM332	UM370	UM430	UM480	EUM430	EUM481	EUM480	Teil-Nr. Part No. No. de pièce No. de pieza	Bezeichnung	Spezifikation Specification	Description	Désignation	Denominación
3	59			2					664 521 350	SCHEIBE		WASHER	RONDELLE	ARANDELA
3	60			2					664 691 810	SCHRAUBE		SCREW	VIS	TORNILLO
3	61			2					664 399 803	GRIFF		KNOB	POIGNÉE	MANETA
3	62			2					664 293 202	MUTTER		NUT	ECROU	TUERCA
3	63			1					664 008 622	SATZ, SCHRAUBEN		OUTFIT, SCREWS	DOTATION VISSERIE	JUEGO DE TORNILLOS
3	251			2					664 293 200	6KT-MUTTER	M8	NUT	ECROU	TUERCA
3	252			2					664 583 500	FEDERRING		GROWER	GROWER	ARANDELA DE PRESIÓN
3	253			2					664 523 070	SCHEIBE		WASHER	RONDELLE	ARANDELA
3	254			2					664 735 547	SEKTOR, HÖHENVERSTELLUNG		SECTOR, HEIGHT ADJUSTMENT	SECTEUR REGLAGE HAUTEUR	SECTOR, AJUSTE ALTURA
3	255			2					664 005 082	RADHALTER		SUPPORT, WHEEL	SUPPORT ROUE	SOPORTE, RUEDA
3	256			2					664 003 285	HEBEL, HÖHENVERSTELLUNG		LEVER, HEIGHT ADJUSTMENT	LEVIER, REGLAGE HAUTEUR	PALANCA, AJUSTE ALTURA
3	257			2					664 171 001	DISTANZRING		SPACER	ENTRETOISE	DISTANCIADOR
3	258			2					664 793 701	SCHRAUBE		SCREW	VIS	TORNILLO
3	258,A			2					664 521 350	SCHEIBE		WASHER	RONDELLE	ARANDELA
3	259			8					664 122 200	LAGER		BEARING	COUSSINET	RODAMIENTO
3	260			2					664 007 336	RAD MIT STOLLENPROFIL	Ø 170	WHEEL, KNOBBLY	ROUE SCULPTEE	RUEDA CON PERFIL
3	261			2					664 521 350	SCHEIBE		WASHER	RONDELLE	ARANDELA
3	262			4					664 155 000	MUTTER		NUT	ECROU	TUERCA
3	263			2					664 110 304	RADKAPPE ROT		HUB CAP RED	COUVRE-MOYEU ROUGE	TAPACUBOS ROJO
3	264			1					664 003 279	RASTHEBEL		LEVER, HEIGHT ADJUSTMENT	LEVIER, REGLAGE HAUTEUR	PALANCA, AJUSTE ALTURA
3	265			2					664 789 000	SCHRAUBE		SCREW	VIS	TORNILLO
3	266			2					664 154 330	MUTTER		NUT	ECROU	TUERCA
3	267			2					664 007 337	RAD MIT STOLLENPROFIL	Ø 210	WHEEL, KNOBBLY	ROUE SCULPTEE	RUEDA CON PERFIL
3	268			2					664 110 305	RADKAPPE ROT		HUB CAP RED	COUVRE-MOYEU ROUGE	TAPACUBOS ROJO
3	269			2					664 369 500	FEDERSCHEIBE		ELASTIC WASHER	DISQUE ELASTIQUE	ARANDELA ELÁSTICA
3	270			2					664 530 150	FEDERSCHEIBE		ELASTIC WASHER	RONDELLE ELASTIQUE	ARANDELA ELÁSTICA
3	401			2					664 120 105	ZAHNRAD		RING GEAR	COURONNE	CORONA DENTADA
3	402			1					664 600 093	SCHUTZ, LINKS RÄDER		PROTECTION, L WHEEL	PROTECTION ROUE G	PROTECCIÓN, RUEDA IZQ.
3	403			4					664 608 600	SICHERUNGSRING		SEEGER	SEEGER	ANILLO DE SEGURIDAD
3	404			1					664 570 120	RITZEL LINKS		PINION L	PIGNON G	PIÑÓN, IZQ.
3	405			2					664 216 035	LAGER		BEARING	COUSSINET	RODAMIENTO
3	406			1					664 600 092	SCHUTZ, RECHTS RÄDER		PROTECTION, R WHEEL	PROTECTION ROUE D	PROTECCIÓN, RUEDA DER.
3	407			1					664 000 147	ACHSE, HINTERRAD		AXLE, REAR WHEELS	AXE ROUES ARRIERE	EJE, RUEDAS TRASERAS
3	408			1					664 570 110	RITZEL RECHTS		PINION R	PIGNON D	PIÑÓN, DER.
3	410			2					664 753 000	STIFT		PIN	GOUPILLE	PASADOR
3	411			1					664 003 076	ANTRIEB	(FRANCE REDUCTEURS)	GEAR BOX	GROUPE TRACTION	UNIDAD DE TRACCIÓN
3	411			1					664 003 081	ANTRIEB (GRAU)	(BI. CI. DI.)	GEAR BOX (GREY)	GROUPE TRACTION	UNIDAD DE TRACCIÓN (GRIS)
3	412			1					664 601 904	RIEMENSCHLEIBE		PULLEY	POULIE	POLEA
3	413			1					664 645 705	STIFT		PIN	GOUPILLE	PASADOR
3	414			1					664 033 280	VERSTELLHEBEL	(BI. CI. DI.)	ADJUSTMENT ROD	TIGE REGLAGE	VÁSTAGO DE AJUSTE



Seite / Page	Pos.	UM332	UM370	UM430	UM480	UM481	UM480	Teil-Nr. Part No. No. de pièce No. de pieza	Bezeichnung	Spezifikation Specification	Description	Désignation	Denominación
3	414			1				664 033 283	VERSTELLHEBEL	(FRANCE REDUCTEURS)	ADJUSTMENT ROD	TIGE REGLAGE	VÁSTAGO DE AJUSTE
3	415			1				664 063 710	KEILRIEMEN	Z 25	BELT	COURROIE	CORREA
3	416			1				664 000 676	KABEL, ANTRIEB OBER	(BI. CI. DI.)	CABLE, REAR DRIVE LOWER	CÂBLE, COMMANDE TRACTION INFERIEURE	CABLE, UNIDAD TRASERA INFERIOR
3	416			1				664 000 671	KABEL, ANTRIEB UNTER	(FRANCE REDUCTEURS)	CABLE, REAR DRIVE LOWER	CÂBLE, COMMANDE TRACTION INFERIEURE	CABLE, UNIDAD TRASERA INFERIOR
3	417			1				664 246 031	VERBINDUNG OBEN		LOWER JOINT	CONNECTION INF	CONEXIÓN INFERIOR
3	418			1				664 042 040	ISOLATION KOMPASS		ISOLATION COMPASS	BOUSSOLE DE	COMPÁS AISLANTE
3	419			1				664 246 030	VERBINDUNG UNTEN		UPPER JOINT	CONNECTION SUP	CONEXIÓN SUPERIOR
3	420			1				664 001 150	KABEL, ANTRIEB OBER		CABLE, REAR DRIVE UPPER	CÂBLE, COMMANDE TRACTION SUPERIEURE	CABLE, UNIDAD TRASERA SUPERIOR
3	421			1				664 041 957	BUCHSE		BUSH	DOUILLE	CASQUILLO
3	422			1				664 450 063	FEDER		SPRING	RESSORT	RESORTE
3	423			1				664 680 009	SCHEIBE		WASHER	RONDELLE	ARANDELA
3	424			1				664 154 510	MUTTER		NUT	ECROU	TUERCA
3	425			1				664 110 230	GUMMISTOPFEN		CAP	BOUCHON	TAPÓN
3	451			1				664 785 061	HALTER, HAUBE		SUPPORT, COVER	SUPPORT CAPOT	SOPORTE, CUBIERTA
3	452			4				664 728 710	SCHRAUBE		SCREW	VIS	TORNILLO
3	453			1				664 563 012	MOTOR RST	230V (1600W)	MOTOR RST	MOTEUR RST	MOTOR RST
3	453,1			1				664 740 051	LÜFTER MOTOR RST		FAN MOTOR RST	VENTILATEUR MOTEUR RST	VENTILADOR MOTOR RST
3	453,2			1				664 222 038	KONDENSATOR	20 µF	CONDENSER	CONDENSEUR	CONDENSADOR
3	454			4				664 735 410	SCHRAUBE		SCREW	VIS	TORNILLO
3	455			4				664 583 500	FEDERRING		GROWER	GROWER	ARANDELA DE PRESIÓN
3	456			4				664 293 200	6KT-MUTTER	M8	NUT	ECROU	TUERCA
3	457			1				664 207 211	FLANSCH		FLANGE	BRIDE	BRIDA
3	458			1				664 720 360	LÜFTUNGSSCHIRM		VENTILATION SCREEN	ECRAN VENTILATION	PANTALLA DE VENTILACIÓN
3	459			4				664 691 800	SCHRAUBE		SCREW	VIS	TORNILLO
3	460			1				664 139 440	KEIL		FEATHER	CLAVETTE	CHAVETA
3	461			1				664 170 960	DISTANZRING		SPACER	ENTRETOISE	DISTANCIADOR
3	501			1				664 463 186	MESSERHALTER		HUB	MOYEU	SOPORTE DE LA CUCHILLA
3	502			1				664 531 043	MESSER	43 CM	BLADE	LAME	CUCHILLA ESTÁNDAR
3	503			2				664 583 500	FEDERRING		GROWER	GROWER	ARANDELA DE PRESIÓN
3	504			2				664 793 101	SCHRAUBE		SCREW	VIS	TORNILLO
3	505			1				664 004 352	MESSERSCHRAUBE		SCREW	VIS	TORNILLO
3	506			1				664 713 801	STIFT		DOWEL	GRAIN	CLAVIJA
3	507			1				664 601 911	RIEMENSCHLEIBE		PULLEY	POUILE	POLEA
3	601			1				664 486 101	KORB, OBERTEIL		GRASS-BOX, UPPER	SAC, PARTIE	CESTO, SUPERIOR
3	602			1				664 608 525	VERSTÄRKUNG		STIFFENING LOWER	RÉNFORCEMENT INF	REFUERZO INFERIOR
3	603			1				664 002 211	SACK, TUCH		BOX, FABRIC	SAC, TOILE	CESTO, TELA
3	604			2				664 728 680	SCHRAUBE		SCREW	VIS	TORNILLO
3	605			2				664 523 050	SCHEIBE		WASHER	RONDELLE	ARANDELA

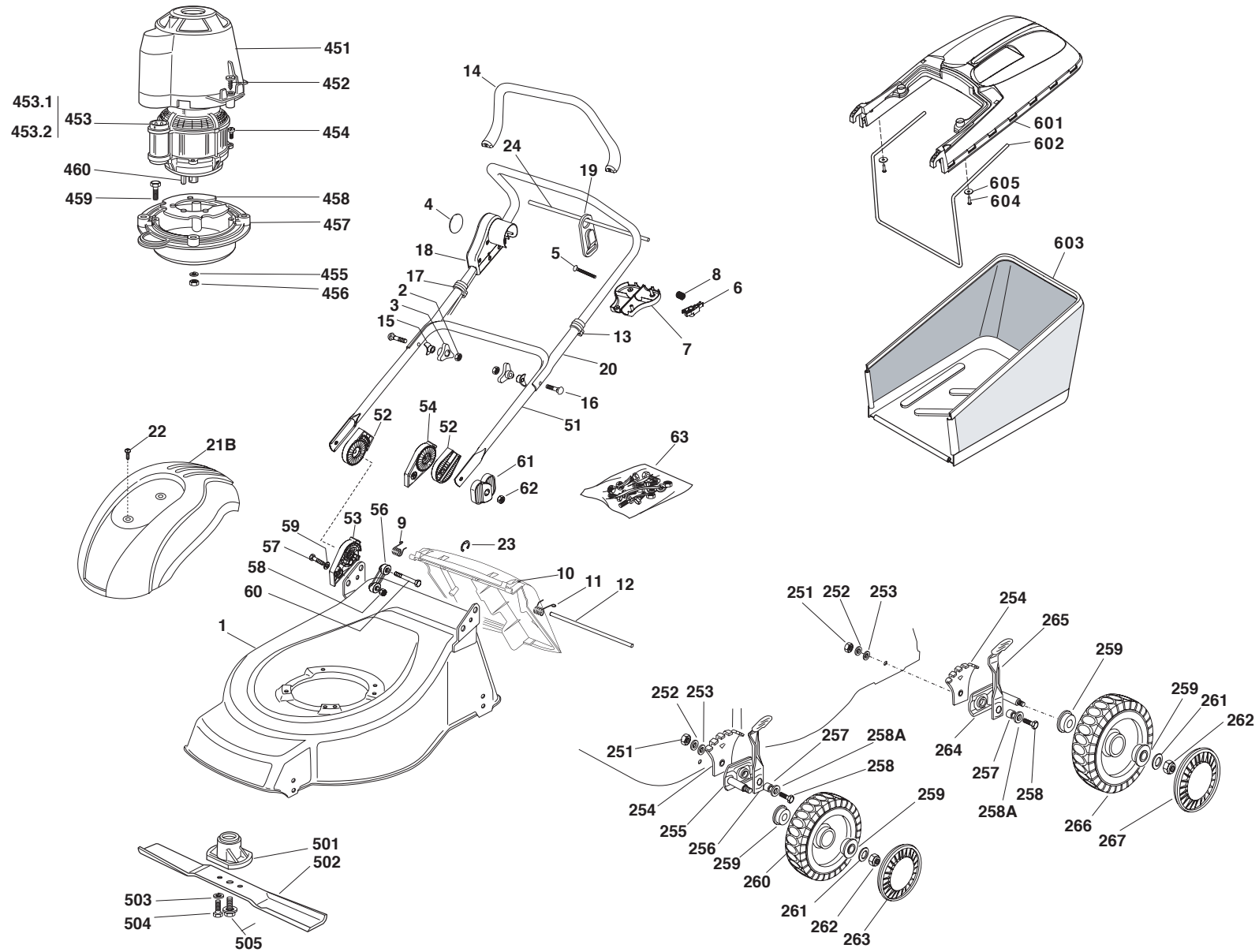



Seite / Page	Pos.	UM332	UM370	UM430	UM480	EUM430	EUM481	EUM480	Teil-Nr. Part No. No. de pièce No. de pieza	Bezeichnung	Spezifikation Specification	Description	Désignation	Denominación
4	1				1				664 002 720	GEHÄUSE ROT		DECK RED	CHÂSSIS ROUGE	CARCASA ROJA
4	2				2				664 293 200	6KT-MUTTER	M8	NUT	ECROU	TUERCA
4	3				2				664 399 900	GRIFF		KNOB	POIGNÉE	MANETA
4	4				1				664 034 601	SCHUTZ		PROTECTION	PROTECTION	PROTECCIÓN
4	5				4				664 728 685	SCHRAUBE		SCREW	VIS	TORNILLO
4	6				1				664 230 350	GELENKPUNKT		FULCRUM PIN	POINT D'APPUI	PUNTO DE ARTICULACIÓN
4	7				1				664 785 144	HALTER		SUPPORT	SUPPORT	SOPORTE
4	8				1				664 450 115	FEDER		SPRING	RESSORT	RESORTE
4	9				1				664 450 410	FEDER RECHTS		R SPRING	RESSORT D	RESORTE DER.
4	10				1				664 600 063	PRALLBLECH		STONE-GUARD	PARE-PIERRES	CUBIERTA PROTECTORA
4	11				1				664 450 420	FEDER LINKS		L SPRING	RESSORT G	RESORTE IZQ.
4	12				1				664 517 906	BOLZEN		PIN	PIVOT	PASADOR
4	13				1				664 192 151	KABELBEFESTIGUNG		FAIRLEAD	FIXATION CABLE	SUJETACABLE
4	14				1				664 322 881	HEBEL, MOTORBREMSE		LEVER, MOTOR BRAKE	LEVIER FREIN MOTEUR	PALANCA, FRENO MOTOR
4	15				2				664 680 006	SCHEIBE		WASHER	RONDELLE	ARANDELA
4	16				2				664 819 201	SCHRAUBE		SCREW	VIS	TORNILLO
4	17				1				664 192 000	BOWDENZUGHALTER		ANCHOR CLAMP	COLLIER ANCRAGE	GRAPA DE SUJECIÓN
4	18				1				664 600 503	TOTMANN-SCHALTER		DEAD HAND SWITCH	INT. MAIN MORTE	INTERRUPTOR DE HOMBRE MUERTO
4	19				1				664 195 101	KABELBEFESTIGUNG		FAIRLEAD	FIXATION CABLE	SUJETACABLE
4	20				1				664 007 017	HOLM, OBERTEIL		HANDLE, UPPER PART	MANCHERON, PARTIE SUPERIEURE	MANILLAR, PARTE SUPERIOR
4	21,B				1				664 055 065	HAUBE		COVER	CAPOT	CUBIERTA
4	22				2				664 728 680	SCHRAUBE		SCREW	VIS	TORNILLO
4	23				1				664 000 930	SPRENGRING		SNAP RING	ANNEAU RESSORT	ANILLO DE SUJECIÓN
4	24				1				664 010 251	KABELHALTER		FAIRLEAD BEARING	SUPPORT SERRECABLE	SOPORTE SUJETACABLE
4	51				1				664 006 532	HOLM, UNTERTEIL		HANDLE, LOWER PART	MANCHERON, PARTIE INFERIEURE	MANILLAR, PARTE INFERIOR
4	52				2				664 785 081	HALTER, AUßEN		SUPPORT, EXTERNAL	SUPPORT EXTERNE	SOPORTE, EXTERIOR
4	53				1				664 785 082	HALTER, INNEN R		SUPPORT, R INTERNAL	SUPPORT INTERNE D	SOPORTE INTERIOR, DER.
4	54				1				664 785 083	HALTER, INNEN L		SUPPORT, L INTERNAL	SUPPORT INTERNE G	SOPORTE INTERIOR, IZQ.
4	56				2				664 551 575	PLATTE, INNEN		PLATE, INSIDE	PLAQUETTE INTERNE	PLANCHA, INTERIOR
4	57				2				664 793 701	SCHRAUBE		SCREW	VIS	TORNILLO
4	58				2				664 155 000	MUTTER		NUT	ECROU	TUERCA
4	59				2				664 521 350	SCHEIBE		WASHER	RONDELLE	ARANDELA
4	60				2				664 691 810	SCHRAUBE		SCREW	VIS	TORNILLO
4	61				2				664 399 803	GRIFF		KNOB	POIGNÉE	MANETA
4	62				2				664 293 202	MUTTER		NUT	ECROU	TUERCA
4	63				1				664 008 622	SATZ, SCHRAUBEN		OUTFIT, SCREWS	DOTATION VISSERIE	JUEGO DE TORNILLOS
4	251				4				664 293 200	6KT-MUTTER	M8	NUT	ECROU	TUERCA
4	252				4				664 583 500	FEDERRING		GROWER	GROWER	ARANDELA DE PRESIÓN
4	253				4				664 523 070	SCHEIBE		WASHER	RONDELLE	ARANDELA
4	254				4				664 735 547	SEKTOR, HÖHENVERSTELLUNG		SECTOR, HEIGHT ADJUSTMENT	SECTEUR REGLAGE HAUTEUR	SECTOR, AJUSTE ALTURA
4	255				2				664 005 082	RADHALTER		SUPPORT, WHEEL	SUPPORT ROUE	SOPORTE, RUEDA



Seite / Page	Pos.	UM332	UM370	UM430	UM480	EUM430	EUM481	EUM480	Teil-Nr. Part No. No. de pièce No. de pieza	Bezeichnung	Spezifikation Specification	Description	Désignation	Denominación
4	256				2				664 003 285	HEBEL, HÖHENVERSTELLUNG		LEVER, HEIGHT ADJUSTMENT	LEVIER, REGLAGE HAUTEUR	PALANCA, AJUSTE ALTURA
4	257				4				664 171 001	DISTANZRING		SPACER	ENTRETOISE	DISTANCIADOR
4	258				4				664 793 701	SCHRAUBE		SCREW	VIS	TORNILLO
4	258,A				4				664 521 350	SCHLEIBE		WASHER	RONDELLE	ARANDELA
4	259				8				664 034 508	BUCHSE		BUSH	DOUILLE	CASQUILLO
4	260				2				664 007 336	RAD MIT STOLLENPROFIL	Ø 170	WHEEL, KNOBBLY	ROUE SCULPTEE	RUEDA CON PERFIL
4	261				4				664 523 060	SCHLEIBE		WASHER	RONDELLE	ARANDELA
4	262				4				664 155 000	MUTTER		NUT	ECROU	TUERCA
4	263				2				664 110 304	RADKAPPE ROT		HUB CAP RED	COUVRE-MOYEU ROUGE	TAPACUBOS ROJO
4	264				2				664 005 084	HALTER, RAD		SUPPORT, WHEEL	SUPPORT ROUE	SOPORTE, RUEDA
4	265				2				664 003 286	HEBEL, HÖHEVERSTELLUNG		LEVER, HEIGHT ADJUSTMENT	LEVIER, REGLAGE HAUTEUR	PALANCA, AJUSTE ALTURA
4	266				2				664 007 337	RAD MIT STOLLENPROFIL	Ø 210	WHEEL, KNOBBLY	ROUE SCULPTEE	RUEDA CON PERFIL
4	267				2				664 110 305	RADKAPPE ROT		HUB CAP RED	COUVRE-MOYEU ROUGE	TAPACUBOS ROJO
4	451				1				664 785 061	HALTER, HAUBE		SUPPORT, COVER	SUPPORT CAPOT	SOPORTE, CUBIERTA
4	452				4				664 728 710	SCHRAUBE		SCREW	VIS	TORNILLO
4	453				1				664 563 605	MOTOR ATB	230V (1600W)	MOTOR ATB	MOTEUR ATB	MOTOR ATB
4	453				1				664 563 009	MOTOR RST	230V (1600W)	MOTOR RST	MOTEUR RST	MOTOR RST
4	453,1				1				664 740 054	LÜFTER MOTOR ATB		FAN MOTOR ATB	VENTILATEUR MOTEUR ATB	VENTILADOR MOTOR ATB
4	453,1				1				664 740 051	LÜFTER MOTOR RST		FAN MOTOR RST	VENTILATEUR MOTEUR RST	VENTILADOR MOTOR RST
4	453,2				1				664 222 038	KONDENSATOR	20 µF	CONDENSER	CONDENSEUR	CONDENSADOR
4	453,2				1				664 222 045	KONDENSATOR	(ATB) 16 µF	CONDENSER	CONDENSEUR	CONDENSADOR
4	454				4				664 735 410	SCHRAUBE		SCREW	VIS	TORNILLO
4	455				4				664 583 500	FEDERRING		GROWER	GROWER	ARANDELA DE PRESIÓN
4	456				4				664 293 200	6KT-MUTTER	M8	NUT	ECROU	TUERCA
4	457				1				664 207 211	FLANSCH		FLANGE	BRIDE	BRIDA
4	458				1				664 720 360	LÜFTUNGSSCHIRM		VENTILATION SCREEN	ECRAN VENTILATION	PANTALLA DE VENTILACIÓN
4	459				4				664 793 700	SCHRAUBE		SCREW	VIS	TORNILLO
4	460				1				664 139 440	KEIL		FEATHER	CLAVETTE	CHAVETA
4	501				1				664 463 186	MESSERHALTER		HUB	MOYEU	SOPORTE DE LA CUCHILLA
4	502				1				664 531 048	MESSER	48 CM	BLADE	LAME	CUCHILLA ESTÁNDAR
4	503				2				664 583 500	FEDERRING		GROWER	GROWER	ARANDELA DE PRESIÓN
4	504				2				664 793 101	SCHRAUBE		SCREW	VIS	TORNILLO
4	505				1				664 004 352	MESSERSCHRAUBE		SCREW	VIS	TORNILLO
4	601				1				664 486 101	KORB, OBERTEIL		GRASS-BOX, UPPER	SAC, PARTIE	CESTO, SUPERIOR
4	602				1				664 608 525	VERSTÄRKUNG		STIFFENING LOWER	RÉNFORCEMENT INF	REFUERZO INFERIOR
4	603				1				664 002 211	SACK, TUCH		BOX, FABRIC	SAC, TOILE	CESTO, TELA
4	604				2				664 728 680	SCHRAUBE		SCREW	VIS	TORNILLO
4	605				2				664 523 050	SCHLEIBE		WASHER	RONDELLE	ARANDELA

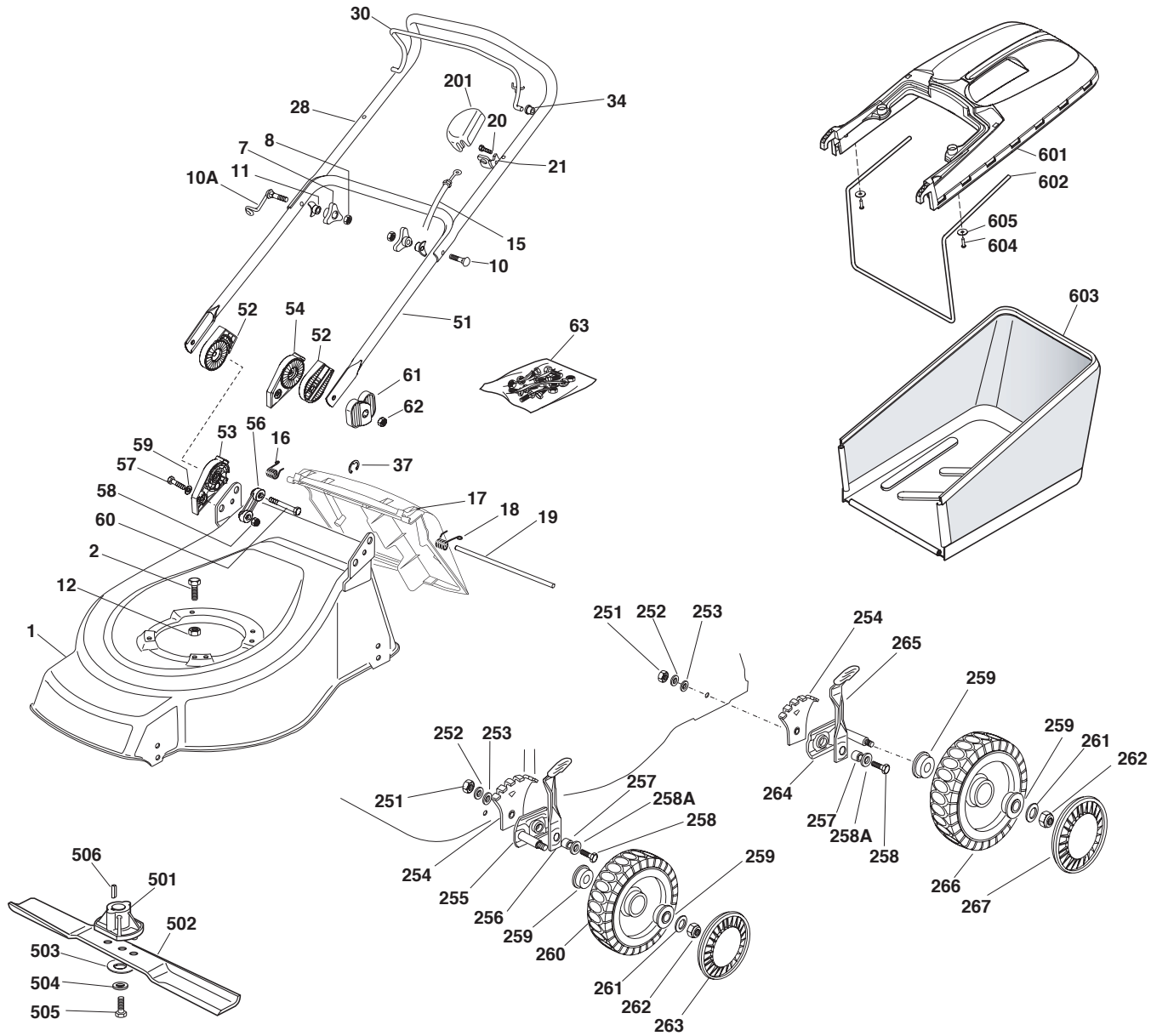



Seite / Page	Pos.	UM332	UM370	UM430	UM480	EUM430	EUM481	EUM480	Teil-Nr. Part No. No. de pièce No. de pieza	Bezeichnung	Spezifikation Specification	Description	Désignation	Denominación
5	1					1			664 002 362	GEHÄUSE ROT		DECK RED	CHÂSSIS ROUGE	CARCASA ROJA
5	2					3/2			664 793 701	SCHRAUBE		SCREW	VIS	TORNILLO
5	2					0/1			664 691 800	SCHRAUBE		SCREW	VIS	TORNILLO
5	7					2			664 399 900	GRIFF		KNOB	POIGNÉE	MANETA
5	8					2			664 293 200	MUTTER		NUT	ECROU	TUERCA
5	10					1			664 819 201	SCHRAUBE		SCREW	VIS	TORNILLO
5	10,A					1			664 003 801	FEDER		SPRING	RESSORT	RESORTE
5	11					2			664 680 006	SCHEIBE		WASHER	RONDELLE	ARANDELA
5	12					0/1			664 155 000	MUTTER		NUT	ECROU	TUERCA
5	12					3/2			664 293 201	MUTTER		NUT	ECROU	TUERCA
5	15					1			664 000 625	KABEL, MOTORBREMSE	(B&S CLASSIC/SPRI NT/LS/LC	CABLE, THREAD MOTOR BRAKE	CABLE FREIN MOTEUR	CABLE, FRENO MOTOR
5	16					1			664 450 410	FEDER RECHTS		R SPRING	RESSORT D	RESORTE DER.
5	17					1			664 600 063	PRALLBLECH		STONE-GUARD	PARE-PIERRES	CUBIERTA PROTECTORA
5	18					1			664 450 420	FEDER LINKS		L SPRING	RESSORT G	RESORTE IZQ.
5	19					1			664 517 906	STANGE		PIN	PIVOT	PASADOR
5	20					1			664 728 518	SCHRAUBE		SCREW	VIS	TORNILLO
5	21					1			664 806 612	HALTER		SUPPORT	SUPPORT	SOPORTE
5	28					1			664 007 018	OBERHOLM		HANDLE, UPPER PART	MANCHERON, PARTIE SUPERIEURE	MANILLAR, PARTE SUPERIOR
5	30					1			664 003 291	TOTMANN-BÜGEL		LEVER, MOTOR BRAKE	LEVIER FREIN MOTEUR	PALANCA, FRENO MOTOR
5	34					2			664 041 966	BUCHSE		BUSH	DOUILLE	CASQUILLO
5	37					1			664 000 930	SPRENGRING		SNAP RING	ANNEAU RESSORT	ANILLO DE SUJECCIÓN
5	51					1			664 006 532	HOLM, UNTERTEIL		HANDLE, LOWER PART	MANCHERON, PARTIE INFERIEURE	MANILLAR, PARTE INFERIOR
5	52					2			664 785 081	HALTER, AUßEN		SUPPORT, EXTERNAL	SUPPORT EXTERNE	SOPORTE, EXTERIOR
5	53					1			664 785 082	HALTER, INNEN R		SUPPORT, R INTERNAL	SUPPORT INTERNE D	SOPORTE INTERIOR, DER.
5	54					1			664 785 083	HALTER, INNEN L		SUPPORT, L INTERNAL	SUPPORT INTERNE G	SOPORTE INTERIOR, IZQ.
5	56					2			664 551 575	PLATTE, INNEN		PLATE, INSIDE	PLAQUETTE INTERNE	PLANCHA, INTERIOR
5	57					2			664 793 701	SCHRAUBE		SCREW	VIS	TORNILLO
5	58					2			664 155 000	MUTTER		NUT	ECROU	TUERCA
5	59					2			664 521 350	SCHEIBE		WASHER	RONDELLE	ARANDELA
5	60					2			664 691 810	SCHRAUBE		SCREW	VIS	TORNILLO
5	61					2			664 399 803	GRIFF		KNOB	POIGNÉE	MANETA
5	62					2			664 293 202	MUTTER		NUT	ECROU	TUERCA
5	63					1			664 008 623	SATZ, SCHRAUBEN		OUTFIT, SCREWS	DOTATION VISSERIE	JUEGO DE TORNILLOS
5	201					1			664 601 000	SCHUTZ		PROTECTION	PROTECTION	PROTECCIÓN
5	251					4			664 293 200	MUTTER		NUT	ECROU	TUERCA
5	252					4			664 583 500	FEDERRING		GROWER	GROWER	ARANDELA DE PRESIÓN
5	253					4			664 523 070	SCHEIBE		WASHER	RONDELLE	ARANDELA
5	254					4			664 735 547	SEKTOR, HÖHENVERSTELLUNG		SECTOR, HEIGHT ADJUSTMENT	SECTEUR REGLAGE HAUTEUR	SECTOR, AJUSTE ALTURA
5	255					2			664 005 082	RADHALTER		SUPPORT, WHEEL	SUPPORT ROUE	SOPORTE, RUEDA



Seite / Page	Pos.	UM332	UM370	UM430	UM480	EUM430	EUM481	EUM480	Teil-Nr. Part No. No. de pièce No. de pieza	Bezeichnung	Spezifikation Specification	Description	Désignation	Denominación
5	256					2			664 003 285	HEBEL, HÖHENVERSTELLUNG		LEVER, HEIGHT ADJUSTMENT	LEVIER, REGLAGE HAUTEUR	PALANCA, AJUSTE ALTURA
5	257					4			664 171 001	DISTANZRING		SPACER	ENTRETOISE	DISTANCIADOR
5	258					4			664 793 701	SCHRAUBE		SCREW	VIS	TORNILLO
5	258,A					4			664 521 350	SCHLEIBE		WASHER	RONDELLE	ARANDELA
5	259					8			664 034 508	BUCHSE		BUSH	DOUILLE	CASQUILLO
5	260					2			664 007 336	RAD MIT STOLLENPROFIL	Ø 170	WHEEL, KNOBBLY	ROUE SCULPTEE	RUEDA CON PERFIL
5	261					4			664 523 060	SCHLEIBE		WASHER	RONDELLE	ARANDELA
5	262					4			664 155 000	MUTTER		NUT	ECROU	TUERCA
5	263					2			664 110 304	RADKAPPE ROT		HUB CAP RED	COUVRE-MOYEU ROUGE	TAPACUBOS ROJO
5	264					2			664 005 084	HALTER, RAD		SUPPORT, WHEEL	SUPPORT ROUE	SOPORTE, RUEDA
5	265					2			664 003 286	HEBEL, HÖHENVERSTELLUNG		LEVER, HEIGHT ADJUSTMENT	LEVIER, REGLAGE HAUTEUR	PALANCA, AJUSTE ALTURA
5	266					2			664 007 337	RAD MIT STOLLENPROFIL	Ø 210	WHEEL, KNOBBLY	ROUE SCULPTEE	RUEDA CON PERFIL
5	267					2			664 110 305	RADKAPPE ROT		HUB CAP RED	COUVRE-MOYEU ROUGE	TAPACUBOS ROJO
5	501					1			664 463 012	MESSERKUPPLUNG		HUB	MOYEU	SOPORTE DE LA CUCHILLA
5	502					1			664 531 043	MESSER	43 CM	BLADE	LAME	CUCHILLA ESTÁNDAR
5	503					1			664 160 400	TELLERFEDER		ELASTIC WASHER	RONDELLE ELASTIQUE	ARANDELA ELÁSTICA
5	504					1			664 523 080	SCHLEIBE		WASHER	RONDELLE	ARANDELA
5	505					1			664 735 698	SCHRAUBE		SCREW	VIS	TORNILLO
5	506					1			664 139 100	SCHLEIBENFEDER		FEATHER	CLAVETTE	CHAVETA
5	601					1			664 486 101	KORB, OBERTEIL		GRASS-BOX, UPPER	SAC, PARTIE	CESTO, SUPERIOR
5	602					1			664 608 525	VERSTÄRKUNG		STIFFENING LOWER	RÉNFORCEMENT INF	REFUERZO INFERIOR
5	603					1			664 002 211	SACK, TUCH		BOX, FABRIC	SAC, TOILE	CESTO, TELA
5	604					2			664 728 680	SCHRAUBE		SCREW	VIS	TORNILLO
5	605					2			664 523 050	SCHLEIBE		WASHER	RONDELLE	ARANDELA



Seite / Page	Pos.	UM332	UM370	UM430	UM480	EUM430	EUM481	EUM480	Teil-Nr. Part No. No. de pièce No. de pieza	Bezeichnung	Spezifikation Specification	Description	Désignation	Denominación
6	1							1	664 002 720	GEHÄUSE ROT		DECK RED	CHÂSSIS ROUGE	CARCASA ROJA
6	2							3/2	664 793 701	SCHRAUBE		SCREW	VIS	TORNILLO
6	2							0/1	664 691 800	SCHRAUBE		SCREW	VIS	TORNILLO
6	7							2	664 399 900	GRIFF		KNOB	POIGNÉE	MANETA
6	8							2	664 293 200	MUTTER		NUT	ECROU	TUERCA
6	10							1	664 819 201	SCHRAUBE		SCREW	VIS	TORNILLO
6	10,A							1	664 003 801	FEDER		SPRING	RESSORT	RESORTE
6	11							2	664 680 006	SCHEIBE		WASHER	RONDELLE	ARANDELA
6	12							0/1	664 155 000	MUTTER		NUT	ECROU	TUERCA
6	12							3/2	664 293 201	MUTTER		NUT	ECROU	TUERCA
6	15							1	664 000 625	KABEL, MOTORBREMSE	(B&S CLASSIC/SPRI NT/LS/LC	CABLE, THREAD MOTOR BRAKE	CABLE FREIN MOTEUR	CABLE, FRENO MOTOR
6	16							1	664 450 410	FEDER RECHTS		R SPRING	RESSORT D	RESORTE DER.
6	17							1	664 600 063	PRALLBLECH		STONE-GUARD	PARE-PIERRES	CUBIERTA PROTECTORA
6	18							1	664 450 420	FEDER LINKS		L SPRING	RESSORT G	RESORTE IZQ.
6	19							1	664 517 906	STANGE		PIN	PIVOT	PASADOR
6	20							1	664 728 518	SCHRAUBE		SCREW	VIS	TORNILLO
6	21							1	664 806 612	HALTER		SUPPORT	SUPPORT	SOPORTE
6	28							1	664 007 018	OBERHOLM		HANDLE, UPPER PART	MANCHERON, PARTIE SUPERIEURE	MANILLAR, PARTE SUPERIOR
6	30							1	664 003 291	TOTMANN-BÜGEL		LEVER, MOTOR BRAKE	LEVIER FREIN MOTEUR	PALANCA, FRENO MOTOR
6	34							2	664 041 966	BUCHSE		BUSH	DOUILLE	CASQUILLO
6	37							1	664 000 930	SPRENGRING		SNAP RING	ANNEAU RESSORT	ANILLO DE SUJECCIÓN
6	51							1	664 006 532	HOLM, UNTERTEIL		HANDLE, LOWER PART	MANCHERON, PARTIE INFERIEURE	MANILLAR, PARTE INFERIOR
6	52							2	664 785 081	HALTER, AUßEN		SUPPORT, EXTERNAL	SUPPORT EXTERNE	SOPORTE, EXTERIOR
6	53							1	664 785 082	HALTER, INNEN R		SUPPORT, R INTERNAL	SUPPORT INTERNE D	SOPORTE INTERIOR, DER.
6	54							1	664 785 083	HALTER, INNEN L		SUPPORT, L INTERNAL	SUPPORT INTERNE G	SOPORTE INTERIOR, IZQ.
6	56							2	664 551 575	PLATTE, INNEN		PLATE, INSIDE	PLAQUETTE INTERNE	PLANCHA, INTERIOR
6	57							2	664 793 701	SCHRAUBE		SCREW	VIS	TORNILLO
6	58							2	664 155 000	MUTTER		NUT	ECROU	TUERCA
6	59							2	664 521 350	SCHEIBE		WASHER	RONDELLE	ARANDELA
6	60							2	664 691 810	SCHRAUBE		SCREW	VIS	TORNILLO
6	61							2	664 399 803	GRIFF		KNOB	POIGNÉE	MANETA
6	62							2	664 293 202	MUTTER		NUT	ECROU	TUERCA
6	63							1	664 008 623	SATZ, SCHRAUBEN		OUTFIT, SCREWS	DOTATION VISSERIE	JUEGO DE TORNILLOS
6	151							1	664 291 000	MUTTER		NUT	ECROU	TUERCA
6	152							1	664 581 500	FEDERRING		GROWER	GROWER	ARANDELA DE PRESIÓN
6	153							1	664 171 005	DISTANZRING		SPACER	ENTRETOISE	DISTANCIADOR
6	154							1	664 521 360	SCHEIBE		WASHER	RONDELLE	ARANDELA
6	155							1	664 508 100	FEDERSCHEIBE		SPRING WASHER	RONDELLE ELASTIQUE	ARANDELA ELÁSTICA
6	156							1	664 007 279	HEBEL, BESCHLEUNIGER		LEVER, THROTTLE	LEVIER,	PALANCA, ACELERADOR



Seite / Page	Pos.	UM332	UM370	UM430	UM480	EUM430	EUM481	EUM480	Teil-Nr. Part No. No. de pièce No. de pieza	Bezeichnung	Spezifikation Specification	Description	Désignation	Denominación
6	157							1	664 007 080	MOTORFERNBEDIENUNG (SATZ)		CABLE, TROTTLE	CABLE, ACCELERATEUR	CABLE, ACELERADOR
6	158							1	664 815 000	SCHRAUBE		SCREW	VIS	TORNILLO
6	159							1	664 356 703	SCHILD	(B&S)	LABEL	ETIQUETTE	ETIQUETA
6	231							1	664 140 223	MULCHEINSATZ	ACC.	MULCH PLUG	INSERT MULCH	TAPA
6	232							1	664 060 198	SCHUTZ		PROTECTION	PROTECTION	PROTECCIÓN
6	233							3	664 728 530	SCHRAUBE		SCREW	VIS	TORNILLO
6	234							1	664 291 150	GUMMIEINSATZ		RUBBER INSERT	INSERT DE	INSERTO DE CAUCHO
6	251							4	664 293 200	MUTTER		NUT	ECROU	TUERCA
6	252							4	664 583 500	FEDERRING		GROWER	GROWER	ARANDELA DE PRESIÓN
6	253							4	664 523 070	SCHEIBE		WASHER	RONDELLE	ARANDELA
6	254							4	664 735 547	SEKTOR, HÖHENVERSTELLUNG		SECTOR, HEIGHT ADJUSTMENT	SECTEUR REGLAGE HAUTEUR	SECTOR, AJUSTE ALTURA
6	255							2	664 005 082	HALTER, RAD		SUPPORT, WHEEL	SUPPORT ROUE	SOPORTE, RUEDA
6	256							2	664 003 285	HEBEL, HÖHENVERSTELLUNG		LEVER, HEIGHT ADJUSTMENT	LEVIER, REGLAGE HAUTEUR	PALANCA, AJUSTE ALTURA
6	257							4	664 171 001	DISTANZRING		SPACER	ENTRETOISE	DISTANCIADOR
6	258							4	664 793 701	SCHRAUBE		SCREW	VIS	TORNILLO
6	258,A							4	664 521 350	SCHEIBE		WASHER	RONDELLE	ARANDELA
6	259							8	664 034 508	BUCHSE		BUSH	DOUILLE	CASQUILLO
6	260							2	664 007 336	RAD MIT STOLLENPROFIL	Ø 170	WHEEL, KNOBBLY	ROUE SCULPTEE	RUEDA CON PERFIL
6	261							4	664 523 060	SCHEIBE		WASHER	RONDELLE	ARANDELA
6	262							4	664 155 000	MUTTER		NUT	ECROU	TUERCA
6	263							2	664 110 304	RADKAPPE ROT		HUB CAP RED	COUVRE-MOYEU ROUGE	TAPACUBOS ROJO
6	264							2	664 005 084	HALTER, RAD		SUPPORT, WHEEL	SUPPORT ROUE	SOPORTE, RUEDA
6	265							2	664 003 286	HEBEL, HÖHENVERSTELLUNG		LEVER, HEIGHT ADJUSTMENT	LEVIER, REGLAGE HAUTEUR	PALANCA, AJUSTE ALTURA
6	266							2	664 007 337	RAD MIT STOLLENPROFIL	Ø 210	WHEEL, KNOBBLY	ROUE SCULPTEE	RUEDA CON PERFIL
6	267							2	664 110 305	RADKAPPE ROT		HUB CAP RED	COUVRE-MOYEU ROUGE	TAPACUBOS ROJO
6	501							1	664 463 012	MESSERKUPPLUNG		HUB	MOYEU	SOPORTE DE LA CUCHILLA
6	502							1	664 531 048	MESSER	48 CM	BLADE	LAME	CUCHILLA ESTÁNDAR
6	503							1	664 160 400	TELLERFEDER		ELASTIC WASHER	RONDELLE ELASTIQUE	ARANDELA ELÁSTICA
6	504							1	664 523 080	SCHEIBE		WASHER	RONDELLE	ARANDELA
6	505							1	664 735 698	SCHRAUBE		SCREW	VIS	TORNILLO
6	506							1	664 139 100	KEIL		FEATHER	CLAVETTE	CHAVETA
6	601							1	664 486 101	KORB, OBERTEIL		GRASS-BOX, UPPER	SAC, PARTIE	CESTO, SUPERIOR
6	602							1	664 608 525	VERSTÄRKUNG		STIFFENING LOWER	RÉNFORCEMENT INF	REFUERZO INFERIOR
6	603							1	664 002 211	SACK, TUCH		BOX, FABRIC	SAC, TOILE	CESTO, TELA
6	604							2	664 728 680	SCHRAUBE		SCREW	VIS	TORNILLO
6	605							2	664 523 050	SCHEIBE		WASHER	RONDELLE	ARANDELA

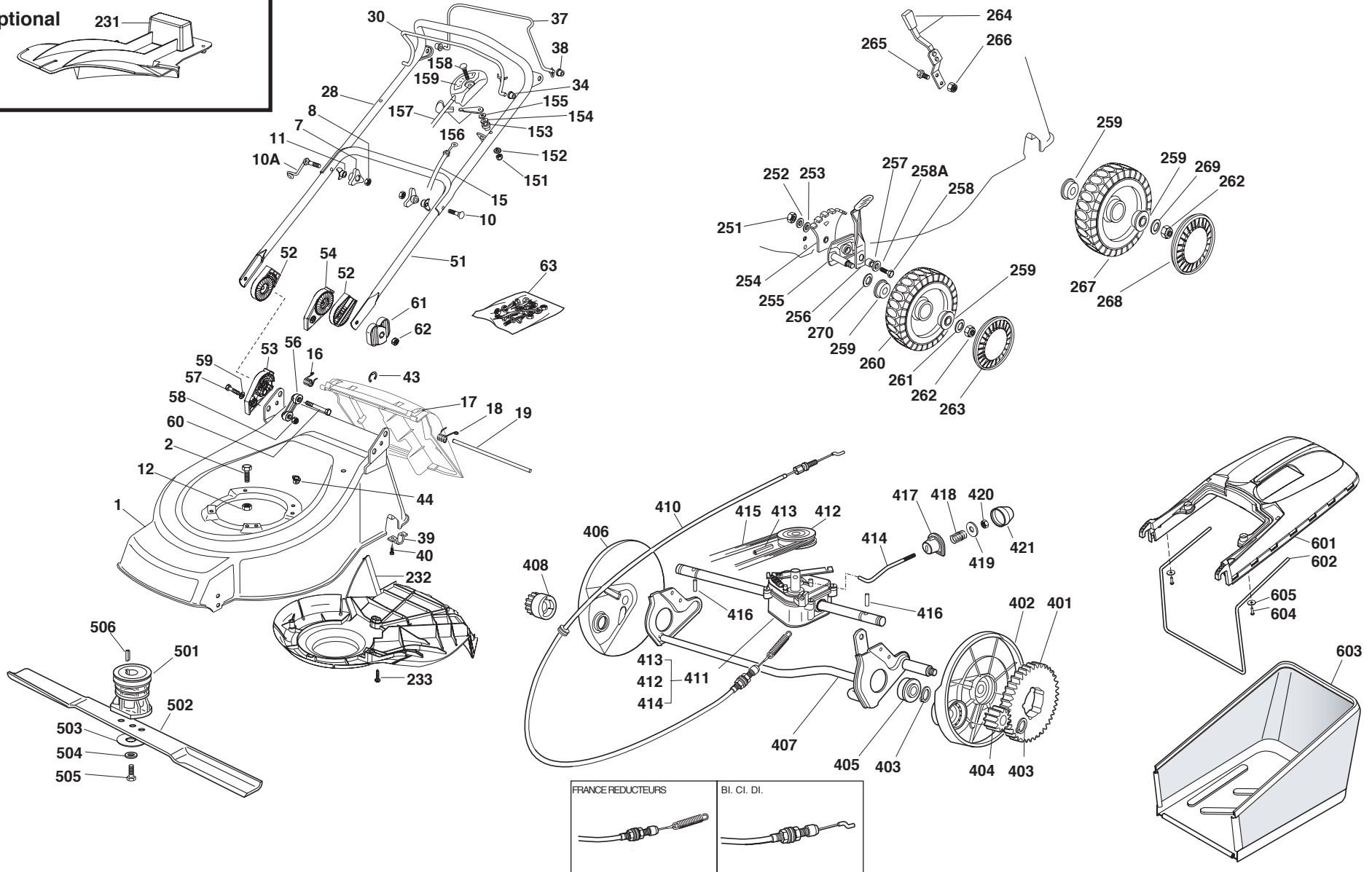
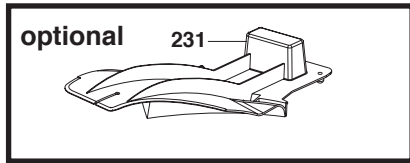



Seite / Page	Pos.	UM332	UM370	UM430	UM480	UM481	UM480	Teil-Nr. Part No. No. de pièce No. de pieza	Bezeichnung	Spezifikation Specification	Description	Désignation	Denominación
7	1						1	664 002 721	GEHÄUSE ROT		DECK RED	CHÂSSIS ROUGE	CARCASA ROJA
7	2						3/2	664 793 701	SCHRAUBE		SCREW	VIS	TORNILLO
7	2						0/1	664 691 800	SCHRAUBE		SCREW	VIS	TORNILLO
7	7						2	664 399 900	GRIFF		KNOB	POIGNÉE	MANETA
7	8						2	664 293 200	MUTTER		NUT	ECROU	TUERCA
7	10						1	664 819 201	SCHRAUBE		SCREW	VIS	TORNILLO
7	10,A						1	664 003 801	FEDER		SPRING	RESSORT	RESORTE
7	11						2	664 680 006	SCHEIBE		WASHER	RONDELLE	ARANDELA
7	12						0/1	664 155 000	MUTTER		NUT	ECROU	TUERCA
7	12						3/2	664 293 201	MUTTER		NUT	ECROU	TUERCA
7	15						1	664 000 625	KABEL, MOTORBREMSE	(B&S CLASSIC/SPRI NT/LS/LC	CABLE, THREAD MOTOR BRAKE	CABLE FREIN MOTEUR	CABLE, FRENO MOTOR
7	16						1	664 450 410	FEDER RECHTS		R SPRING	RESSORT D	RESORTE DER.
7	17						1	664 600 063	PRALLBLECH		STONE-GUARD	PARE-PIERRES	CUBIERTA PROTECTORA
7	18						1	664 450 420	FEDER LINKS		L SPRING	RESSORT G	RESORTE IZQ.
7	19						1	664 517 906	STANGE		PIN	PIVOT	PASADOR
7	28						1	664 007 024	OBERHOLM		HANDLE, UPPER PART	MANCHERON, PARTIE SUPERIEURE	MANILLAR, PARTE SUPERIOR
7	30						1	664 003 291	TOTMANN-BÜGEL		LEVER, MOTOR BRAKE	LEVIER FREIN MOTEUR	PALANCA, FRENO MOTOR
7	34						2	664 041 966	BUCHSE		BUSH	DOUILLE	CASQUILLO
7	37						1	664 003 288	BÜGEL		LEVER, DRIVING	LEVIER TRACTION	PALANCA, CONDUCCIÓN
7	38						2	664 041 965	BUCHSE		BUSH	DOUILLE	CASQUILLO
7	39						2	664 545 152	LAGERSCHALE		PLATE	PLAQUETTE	COJINETE
7	40						4	664 731 350	SCHRAUBE		SCREW	VIS	TORNILLO
7	43						1	664 000 930	SPRENGRING		SNAP RING	ANNEAU RESSORT	ANILLO DE SUJECIÓN
7	44						1	664 291 150	GUMMIEINSATZ		RUBBER INSERT	INSERT DE	INSERTO DE CAUCHO
7	51						1	664 006 532	HOLM, UNTERTEIL		HANDLE, LOWER PART	MANCHERON, PARTIE INFERIEURE	MANILLAR, PARTE INFERIOR
7	52						2	664 785 081	HALTER, AUßEN		SUPPORT, EXTERNAL	SUPPORT EXTERNE	SOPORTE, EXTERIOR
7	53						1	664 785 082	HALTER, INNEN R		SUPPORT, R INTERNAL	SUPPORT INTERNE D	SOPORTE INTERIOR, DER.
7	54						1	664 785 083	HALTER, INNEN L		SUPPORT, L INTERNAL	SUPPORT INTERNE G	SOPORTE INTERIOR, IZQ.
7	56						2	664 551 575	PLATTE, INNEN		PLATE, INSIDE	PLAQUETTE INTERNE	PLANCHA, INTERIOR
7	57						2	664 793 701	SCHRAUBE		SCREW	VIS	TORNILLO
7	58						2	664 155 000	MUTTER		NUT	ECROU	TUERCA
7	59						2	664 521 350	SCHEIBE		WASHER	RONDELLE	ARANDELA
7	60						2	664 691 810	SCHRAUBE		SCREW	VIS	TORNILLO
7	61						2	664 399 803	GRIFF		KNOB	POIGNÉE	MANETA
7	62						2	664 293 202	MUTTER		NUT	ECROU	TUERCA
7	63						1	664 008 623	SATZ, SCHRAUBEN		OUTFIT, SCREWS	DOTATION VISSERIE	JUEGO DE TORNILLOS
7	151						1	664 291 000	MUTTER		NUT	ECROU	TUERCA
7	152						1	664 581 500	FEDERRING		GROWER	GROWER	ARANDELA DE PRESIÓN
7	153						1	664 171 005	DISTANZRING		SPACER	ENTRETOISE	DISTANCIADOR



Seite / Page	Pos.	UM332	UM370	UM430	UM480	EUM430	EUM481	EUM480	Teil-Nr. Part No. No. de pièce No. de pieza	Bezeichnung	Spezifikation Specification	Description	Désignation	Denominación
7	154							1	664 521 360	SCHEIBE		WASHER	RONDELLE	ARANDELA
7	155							1	664 508 100	FEDERSCHEIBE		SPRING WASHER	RONDELLE ELASTIQUE	ARANDELA ELÁSTICA
7	156							1	664 007 279	HEBEL, BESCHLEUNIGER		LEVER, THROTTLE	LEVIER,	PALANCA, ACELERADOR
7	157							1	664 007 080	MOTORFERNBEDIENUNG (SATZ)		CABLE, TROTTLE	CABLE, ACCELERATEUR	CABLE, ACELERADOR
7	158							1	664 815 000	SCHRAUBE		SCREW	VIS	TORNILLO
7	159							1	664 356 703	SCHILD	(B&S)	LABEL	ETIQUETTE	ETIQUETA
7	231							1	664 140 223	MULCHEINSATZ	ACC.	MULCH PLUG	INSERT MULCH	TAPA
7	232							1	664 060 198	SCHUTZ		PROTECTION	PROTECTION	PROTECCIÓN
7	233							2	664 728 530	SCHRAUBE		SCREW	VIS	TORNILLO
7	251							2	664 293 200	MUTTER		NUT	ECROU	TUERCA
7	252							2	664 583 500	FEDERING		GROWER	GROWER	ARANDELA DE PRESIÓN
7	253							2	664 523 070	SCHEIBE		WASHER	RONDELLE	ARANDELA
7	254							2	664 735 547	SEKTOR, HÖHENVERSTELLUNG		SECTOR, HEIGHT ADJUSTMENT	SECTEUR REGLAGE HAUTEUR	SECTOR, AJUSTE ALTURA
7	255							2	664 005 082	RADHALTER		SUPPORT, WHEEL	SUPPORT ROUE	SOPORTE, RUEDA
7	256							2	664 003 285	HEBEL, HÖHENVERSTELLUNG		LEVER, HEIGHT ADJUSTMENT	LEVIER, REGLAGE HAUTEUR	PALANCA, AJUSTE ALTURA
7	257							2	664 171 001	DISTANZRING		SPACER	ENTRETOISE	DISTANCIADOR
7	258							2	664 793 701	SCHRAUBE		SCREW	VIS	TORNILLO
7	258,A							2	664 521 350	SCHEIBE		WASHER	RONDELLE	ARANDELA
7	259							8	664 122 200	KUGELLAGER		BEARING	COUSSINET	RODAMIENTO
7	260							2	664 007 336	RAD MIT STOLLENPROFIL	Ø 170	WHEEL, KNOBBLY	ROUE SCULPTEE	RUEDA CON PERFIL
7	261							2	664 521 350	SCHEIBE		WASHER	RONDELLE	ARANDELA
7	262							4	664 155 000	MUTTER		NUT	ECROU	TUERCA
7	263							2	664 110 304	RADKAPPE ROT		HUB CAP RED	COUVRE-MOYEU ROUGE	TAPACUBOS ROJO
7	264							1	664 003 279	RASTHEBEL		LEVER, HEIGHT ADJUSTMENT	LEVIER, REGLAGE HAUTEUR	PALANCA, AJUSTE ALTURA
7	265							2	664 789 000	SCHRAUBE		SCREW	VIS	TORNILLO
7	266							2	664 154 330	MUTTER		NUT	ECROU	TUERCA
7	267							2	664 007 337	RAD MIT STOLLENPROFIL	Ø 210	WHEEL, KNOBBLY	ROUE SCULPTEE	RUEDA CON PERFIL
7	268							2	664 110 305	RADKAPPE ROT		HUB CAP RED	COUVRE-MOYEU ROUGE	TAPACUBOS ROJO
7	269							2	664 369 500	FEDERSCHEIBE		ELASTIC WASHER	DISQUE ELASTIQUE	ARANDELA ELÁSTICA
7	270							2	664 530 150	FEDERSCHEIBE		ELASTIC WASHER	RONDELLE ELASTIQUE	ARANDELA ELÁSTICA
7	401							2	664 120 105	ZAHNRAD		RING GEAR	COURONNE	CORONA DENTADA
7	402							1	664 600 093	SCHUTZ, LINKS RÄDER		PROTECTION, L WHEEL	PROTECTION ROUE G	PROTECCIÓN, RUEDA IZQ.
7	403							4	664 608 600	SICHERUNGSRING		SEEGER	SEEGER	ANILLO DE SEGURIDAD
7	404							1	664 570 120	RITZEL LINKS		PINION L	PIGNON G	PIÑÓN, IZQ.
7	405							2	664 216 035	LAGER		BEARING	COUSSINET	RODAMIENTO
7	406							1	664 600 092	SCHUTZ, RECHTS RÄDER		PROTECTION, R WHEEL	PROTECTION ROUE D	PROTECCIÓN, RUEDA DER.
7	407							1	664 000 147	ACHSE, HINTERRAD		AXLE, REAR WHEELS	AXE ROUES ARRIERE	EJE, RUEDAS TRASERAS
7	408							1	664 570 110	RITZEL RECHTS		PINION R	PIGNON D	PIÑÓN, DER.
7	410							1	664 000 668	KABEL, ANTRIEB	(FRANCE REDUCTEURS)	CABLE, REAR DRIVE	CÂBLE, COMMANDE TRACTION	CABLE, UNIDAD TRASERA
7	410							1	664 000 672	KABEL, ANTRIEB	(BI. CI. DI.)	CABLE, REAR DRIVE	CÂBLE, COMMANDE TRACTION	CABLE, UNIDAD TRASERA



Seite / Page	Pos.	UM332	UM370	UM430	UM480	UM481	UM480	Teil-Nr. Part No. No. de pièce No. de pieza	Bezeichnung	Spezifikation Specification	Description	Désignation	Denominación
7	411						1	664 003 076	ANTRIEB	(FRANCE REDUCTEURS)	GEAR BOX	GROUPE TRACTION	UNIDAD DE TRACCIÓN
7	411						1	664 003 081	ANTRIEB (GRAU)	(BI. CI. DI.)	GEAR BOX (GREY)	GROUPE TRACTION	UNIDAD DE TRACCIÓN (GRIS)
7	412						1	664 601 904	RIEMENSCHLEIBE		PULLEY	POULIE	POLEA
7	413						1	664 645 705	STIFT		PIN	GOUILLE	PASADOR
7	414						1	664 033 280	VERSTELLHEBEL	(BI. CI. DI.)	ADJUSTMENT ROD	TIGE REGLAGE	VÁSTAGO DE AJUSTE
7	414						1	664 033 283	VERSTELLHEBEL	(FRANCE REDUCTEURS)	ADJUSTMENT ROD	TIGE REGLAGE	VÁSTAGO DE AJUSTE
7	415						1	664 063 800	KEILRIEMEN	Z 27	BELT	COURROIE	CORREA
7	416						2	664 753 000	STIFT		PIN	GOUILLE	PASADOR
7	417						1	664 041 957	BUCHSE		BUSH	DOUILLE	CASQUILLO
7	418						1	664 450 063	FEDER		SPRING	RESSORT	RESORTE
7	419						1	664 680 009	SCHEIBE		WASHER	RONDELLE	ARANDELA
7	420						1	664 154 510	MUTTER		NUT	ECROU	TUERCA
7	421						1	664 110 230	GUMMISTOPFEN		CAP	BOUCHON	TAPÓN
7	501						1	664 465 607	MESSERKUPPLUNG		HUB WITH PULLEY	MOYEU AVEC POULIE	SOPORTE DE LA CUCHILLA CON POLEA
7	502						1	664 531 048	MESSER	48 CM	BLADE	LAME	CUCHILLA ESTÁNDAR
7	503						1	664 160 400	TELLERFEDER		ELASTIC WASHER	RONDELLE ELASTIQUE	ARANDELA ELÁSTICA
7	504						1	664 523 080	SCHEIBE		WASHER	RONDELLE	ARANDELA
7	505						1	664 735 698	SCHRAUBE		SCREW	VIS	TORNILLO
7	506						1	664 139 100	SCHEIBENFEDER		FEATHER	CLAVETTE	CHAVETA
7	601						1	664 486 101	KORB, OBERTEIL		GRASS-BOX, UPPER	SAC, PARTIE	CESTO, SUPERIOR
7	602						1	664 608 525	VERSTÄRKUNG		STIFFENING LOWER	RÉNFORCEMENT INF	REFUERZO INFERIOR
7	603						1	664 002 211	SACK, TUCH		BOX, FABRIC	SAC, TOILE	CESTO, TELA
7	604						2	664 728 680	SCHRAUBE		SCREW	VIS	TORNILLO
7	605						2	664 523 050	SCHEIBE		WASHER	RONDELLE	ARANDELA

1	UM332
2	UM370
3	UM430
4	UM480
5	EUM430
6	EUM481
7	EUM480

	Zeichenerklärung	Key to symbols	Légende	Explicación de símbolos
1999999 2000000 2003.04 TI 2003/07 Acc. = { m Corr.	Produktion bis Serien-Nr. Neues Teil ab Serien-Nr. Neues Teil ab Jahr / Monat Siehe Technische Information Jahr / Nr. Zubehör (nicht im Lieferumfang) Keine Serienausführung, jedoch verwendbar Beinhaltet Positions-Nr. Meterware Druckfehlerberichtigung	Production to serial number New part from serial number New part from Year / Month See Technical Information Year / No. Accessories (not included in the delivery inventory) No standard execution, may be used Contains item number Sold by the meter Error correction	Production jusqu'à n° de série Nouvelle pièce à partir du n° de série Nouvelle pièce à partir de année / mois Voir information technique année / n° Accessoires (non compris dans la livraison) Aucune exécut. en série, cependant utilisable contient n° de numéro Au mètre Rectification d'erreurs	Producción hasta N° de serie Pieza nueva a partir de N° de serie Pieza nueva a partir de año / mes Véase inform. técnico año / N° Accesorios (no incluido en la extensión del suministro) No es de serie, pero sirve Contiene pos N° Por metro Fe de erratas
	Änderungen vorbehalten	Specifications subject to change without notice	Changements sans préavis	Mejoras constructivas sin previo aviso