



Spare Parts List
Ersatzteilliste
Liste de pièces détachées
Lista de piezas de repuesto

2011-05



UV380
EUV400

995700622 (D, GB, F, E)

Seite / Page	Pos.	UV380	Teil-Nr. Part No. No. de pièce No. de pieza	Hinweise Notes Renseign. Nota	Bezeichnung	Spezifikation Specification	Description	Désignation	Denominación
1a	1	1	683 043 090		HAUBE, BLAU		DECK, BLUE	CAPOT, BLEU	CAPOTA, AZUL
1a	2	2	684 018 490		LAGERGEHÄUSE		BUSHING	LOGEMENT	SOPORTE
1a	3	2	684 018 480		LAGERBUCHSE		BEARING HOLDER	DOUILLE	CASQUILLO
1a	4	2	682 018 470		LAGER	17x40x12 6203 RS	BEARING	ROULEMENT	CUSCINETTO
1a	5	6	680 147 490		SCHRAUBE	M 6x20 UNI 5739	SCREW	VIS	TORNILLO
1a	6	14	680 144 370		SCHEIBE	M 6x18 UNI 6593	WASHER	RONDELLE	ARANDELA
1a	7	6	680 145 990		SCHRAUBE	3,9x19 UNI 6954	SCREW	VIS	TORNILLO
1a	8	2	680 140 080		SCHRAUBE	4,0x25 UNI 9708	SCREW	VIS	TORNILLO
1a	9	2	682 022 180		GRIFF		KNOB	POIGNÉE	ASA
1a	10	2	680 456 760		ZWISCHENSTÜCK		CLAMP	PIÈCE INTERMÉDIAIRE	PIEZA INTERMEDIA
1a	11	17	920 406 000		SECHSKANTMUTTER	M6	HEX NUT	ECROU HEXAGONAL	TUERCA HEXAGONAL
1a	12	2	680 456 750		KLEMME		CLAMP	PINCE	BORNE
1a	13	2	682 025 880		TREIBBRAD		PULLEY	POULIE RÉCEPTRICE	POLEA
1a	14	1	680 243 570		KEILRIEMEN	XZ-21	BELT	COURROIE	CORREA
1a	15	3	680 144 480		SCHEIBE	M 8x24 UNI 6593	WASHER	RONDELLE	ARANDELA
1a	16	7	680 109 540		SCHRAUBE	M 8x16 UNI 5739	SCREW	VIS	TORNILLO
1a	17	2	684 018 460		ABSTANDHALTER		SPACER	ECARTEUR	SEPARADOR
1a	18	1	682 018 440		MESSERWELLE		BLADE HOLDER SHAFT	PORTE-LAME	ÁRBOL DE CUCHILLAS
1a	19	15	682 018 430		MESSER		BLADE	LAME	CUCHILLAS
1a	20	14	684 018 450		ABSTANDSBUCHSE		SPACER BUSH	DOUILLE D'ÉCARTEMENT	CASQUILLO SEPARACIÓN
1a	21	2	680 145 960		SCHRAUBE	M 6x45 UNI 5739	SCREW	VIS	TORNILLO
1a	22	2	680 170 520		SCHEIBE	M 6 UNI 6592	WASHER	RONDELLE	ARANDELA
1a	23	2	680 142 000		MUTTER	M 6 UNI 5588	NUT	ECROU	TUERCA
1a	24	1	683 018 350		STANGE		BAR	TRINGLE	BARRA
1a	25	1	682 024 530		HUTMUTTER	M 6	CAP NUT	ECROU BORGNE	TUERCA DE SOMBRETERE
1a	26	2	681 022 210		SCHRAUBE	M 6x16	SCREW	VIS	TORNILLO
1a	27	2	682 022 260		KLEMM-MUTTER	M 6	CLAMPING NUT	ECROU DE CALAGE	TUERCA DE APRIETE
1a	28	2	680 142 360		FÄCHERSCHEIBE	M 6 DIN 6798	WASHER	RONDELLE	ARANDELA
1a	29	1	682 019 080		FEDER		SPRING	RESSORT	MUELLE
1a	30	1	682 024 080		STELLRAD		ADJUSTMENT WHEEL	ROUE DE RÉGLAGE	RUEDA DE AJUSTE
1a	31	1	683 022 290		STANGE		BAR	TRINGLE	BARRA
1a	32	8	680 142 760		SCHRAUBE	M 6x16 UNI 5739	SCREW	VIS	TORNILLO
1a	33	4	684 018 330		ACHSLAGER		AXLE BEARING	PALIER	COJINETE DEL EJE
1a	34	2	683 018 310		ACHSE		AXLE	ESSIEU AVANT	EJE
1a	35	4	680 145 250		FEDERSCHEIBE		SPRING WASHER	RONDELLE A RESSORT	ARANDELA ELASTICO
1a	36	8	680 245 240		SICHERUNGSRING	13x19x1 DIN 988	CIRCLIP	ANNEAU D'ÉTANCHÉITÉ	CIRCLIP
1a	37	8	680 203 680		LAGER	12x26x12,4	BEARING	ROULEMENT	COJINETE
1a	38	4	683 006 790		RAD	Ø=200/26	WHEEL	ROUE	RUEDA
1a	39	18	680 144 460		SCHEIBE	M 8 UNI 6592	WASHER	RONDELLE	ARANDELA
1a	40	6	680 142 030		MUTTER	M 8 UNI 5588	NUT	ECROU	TUERCA
1a	41	4	684 023 370		RADKAPPE, SCHWARZ		WHEEL COVER, BLACK	CHAPEAU DE MOYEU, NOIR	CAPERUZA DE RUEDA, NEGRO
1a	42	1	684 022 450		RIEMENABDECKUNG, SCHWARZ		BELT COVER, BLACK	COUVERCLE DE COURROIE, NOIR	CUBIERTA DE CORREA, NEGRO
1a	43	1	681 017 300		SCHRAUBE		SCREW	VIS	TORNILLO
1a	44	10	680 144 450		MUTTER	M 8 DIN 985 (B&S 3,5)	NUT	ECROU	TUERCA
1a	45	8	680 152 560		SCHRAUBE	M 8x20 UNI 5739	SCREW	VIS	TORNILLO
1a	46	1	682 021 910		STANGE GRASKLAPPE		GRASS FLAP ROD	TRINGLE TRAPPE À HERBE	BARRA TAPA DE YERBA
1a	47	2	680 145 900		SICHERUNGSSCHEIBE	D=7	LOCK WASHER	RONDELLE D'ARRÊT	ARANDELA DE SEGURIDAD
1a	48	1	684 018 300		GRASKLAPPE		GRASS FLAP	TRAPPE À HERBE	TAPA PARA YERBA
1a	49	1	682 019 770		FEDER		SPRING	RESSORT	MUELLE
1a	50	1	683 008 010		GRIFFTRÄGER LINKS		LEFT HANDLE SUPPORT	SUPPORT DE POIGNÉE GAUCHE	SOPORTE DE ASA IZQUIERDO

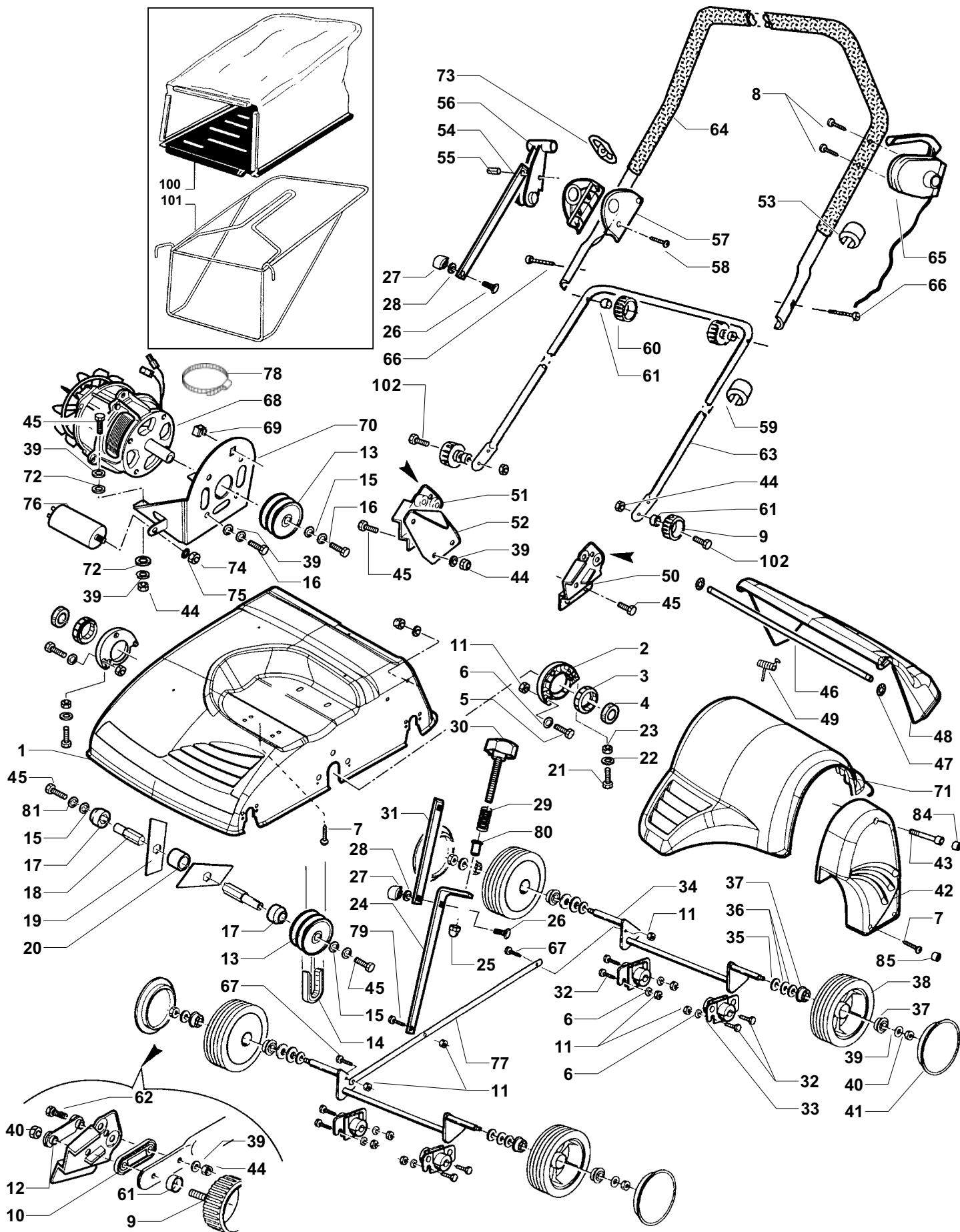

Seite / Page	Pos.	UV380	Teil-Nr. Part No. No. de pièce No. de pieza	Hinweise Notes Renseign. Nota	Bezeichnung	Spezifikation Specification	Description	Désignation	Denominación
1a	51	1	683 008 000		GRIFFRÄGER RECHTS		RIGHT HANDLE SUPPORT	SUPPORT DE POIGNÉE DROITE	SOPORTE DE ASA DERECHO
1a	52	1	683 018 380		GRUNDPLATTE		SUPPORT	PLAQUE D'ASSISE	BASE
1a	53	1	680 446 340		KABELCLIPP		CABLE CLIP	CLIP DE CÂBLE	CLIP PARA CABLE
1a	54	1	683 018 360		STANGE		BAR	TRINGLE	BARRA
1a	55	1	681 021 900		STIFT		PIN	CHEVILLE	PASADOR
1a	56	1	684 018 390		HEBEL		LEVER	LEVIER	PALANCA
1a	57	2	684 018 400		HEBELTRÄGER		LEVER SUPPORT	SUPPORT DE LEVIER	SOPORTE DE PALANCA
1a	58	4	681 022 110		SCHRAUBE	3,9x25	SCREW	VIS	TORNILLO
1a	59	1	680 446 330		KABELCLIPP		CABLE CLIP	CLIP DE CÂBLE	CLIP PARA CABLE
1a	60	2	682 008 490		KLEMMMUTTER	M 8	CLAMPING NUT	ECROU DE CALAGE	TUERCA DE APRIETE
1a	61	4	680 340 060		SCHEIBE		WASHER	RONDELLE	ARANDELA
1a	62	2	680 184 540		SCHRAUBE	M 8x30 UNI 5739	SCREW	VIS	TORNILLO
1a	63	1	683 018 410		UNTERHOLM		LOWER HANDLE	MANCHE INFÉRIEURE	MANGO INFERIOR
1a	64	1	683 021 960		OBERHOLM		UPPER HANDLE	MANCHE SUPÉRIEURE	MANGO SUPERIOR
1a	65	1	682 022 160		SCHALTER		SWITCH	COMMUTATEUR	INTERRUPTOR
1a	66	2	680 101 740		SCHRAUBE	M 8x55	SCREW	VIS	TORNILLO
1a	67	2	681 024 440		SCHRAUBE	M 6x20 UNI 5933	SCREW	VIS	TORNILLO
1a	68	1	682 066 920		MOTOR	1800 W	MOTOR	MOTEUR	MOTOR
1a	69	1	682 016 350		KLAMMER		CLAMP	BRIDE DE FIXATION	GRAPA
1a	70	1	683 018 540		MOTORTRÄGER KPL.		MOTOR HOUSING, CPL.	CARTER DE MOTEUR CPL.	CÁRTER DE MOTOR CPL.
1a	71	1	684 022 460		MOTORABDECKUNG, SCHWARZ		MOTOR COVER, BLACK	COUVERTURE MOTEUR, NOIR	CUBIERTA DEL MOTOR, NEGRO
1a	72	8	682 019 780		BUCHSE		BUSHING	DOUILLE	CASQUILLO
1a	73	1	680 409 570		ZUGENTLASTUNG KABEL		STRAIN RELIEF CABLE	DÉCONTRACTION CÂBLE	CABLE DESCARGA DE TRACCIÓN
1a	74	1	680 146 410		MUTTER	M 8 UNI 5589	NUT	ECROU	TUERCA
1a	75	1	680 145 480		SCHEIBE	M 8 DIN 6798	WASHER	RONDELLE	ARANDELA
1a	76	1	680 247 600		KONDENSATOR	16µF	CAPACITOR	CONDENSATEUR	CONDENSADOR
1a	77	1	683 024 310		TRAVERSE		CROSSBAR	TRAVERSE	TRAVIESA
1a	78	1	682 017 440		KABELBINDER		CLIP	BRIDE DE FIXATION	ABRAZADERA
1a	79	1	681 024 450		SCHRAUBE	M 6x18 UNI 5739	SCREW	VIS	TORNILLO
1a	80	1	682 025 460		BUCHSE		BUSH	DOUILLE	CASQUILLO
1a	81	7	680 145 480		SCHEIBE	M 8 DIN 6798	WASHER	RONDELLE	ARANDELA
1a	84	1	680 035 600		ISOLIERKAPPE	D=14,5	INSULATING CAP	CHAPE D'ISOLATION	CUBIERTO DE AISLADOR
1a	85	2	680 035 610		ISOLIERKAPPE	D=9,5	INSULATING CAP	CHAPE D'ISOLATION	CUBIERTO DE AISLADOR
1a	100	1	682 043 100		GRASSACK	MAKITA	GRASS BAG	SAC À HERBE	SACO PARA YERBA
1a	101	1	683 018 550		RAHMEN		FRAME	CADRE	MARCO
1a	102	2	680 172 960		SCHRAUBE	M8x35 UNI 5739	H.H. SCREW	VIS	TORNILLO

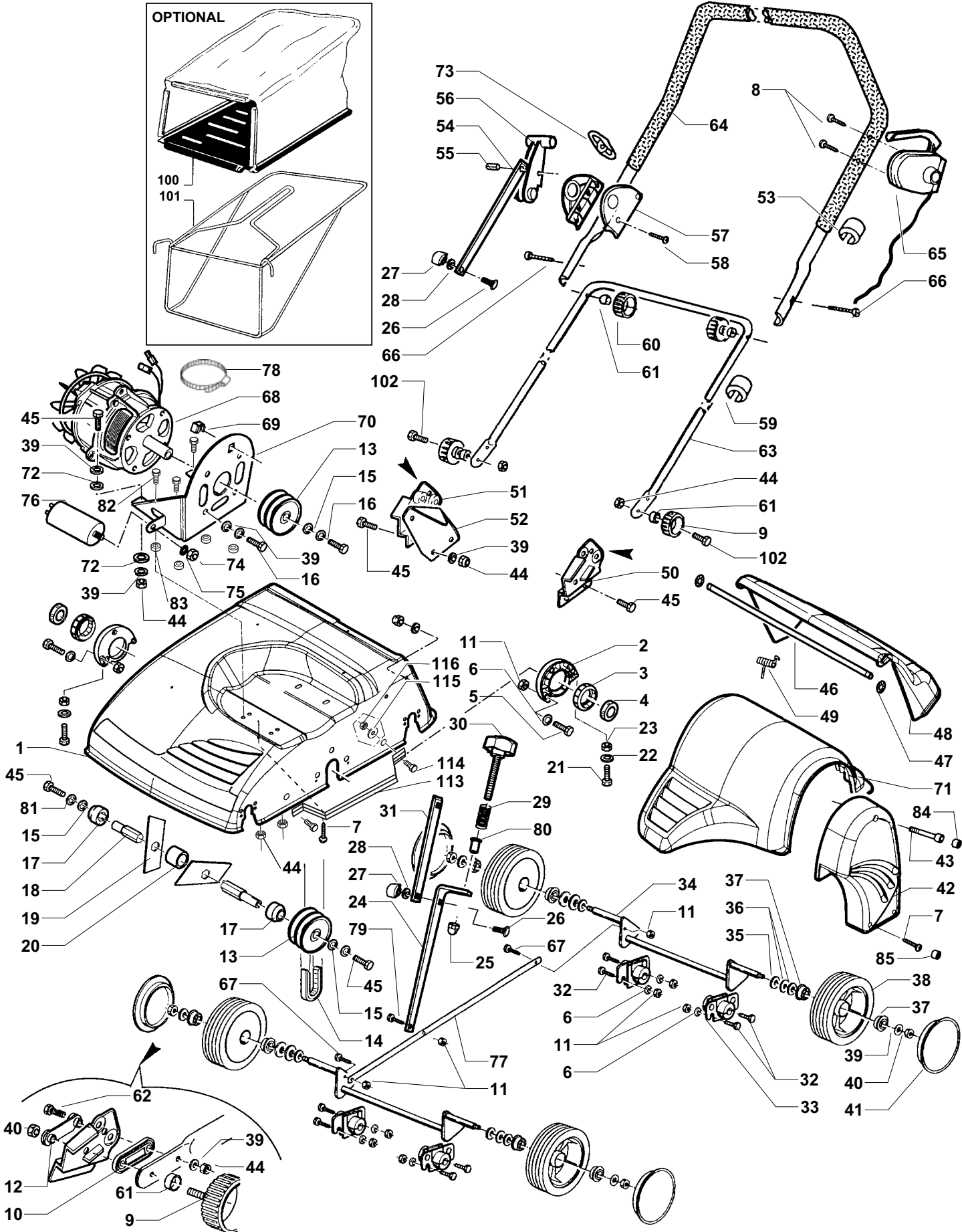
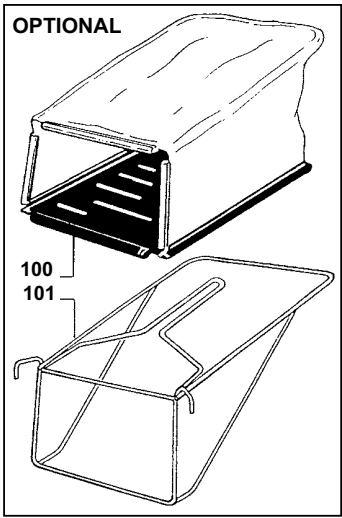

Seite / Page	Pos.	UV380	Teil-Nr. Part No. No. de pièce No. de pieza	Hinweise Notes Renseign. Nota	Bezeichnung	Spezifikation Specification	Description	Désignation	Denominación
1b	1	1	683 043 090		HAUBE, BLAU		DECK, BLUE	CAPOT, BLEU	CAPOTA, AZUL
1b	2	2	684 018 490		LAGERGEHÄUSE		BUSHING	LOGEMENT	SOPORTE
1b	3	2	684 018 480		LAGERBUCHSE		BEARING HOLDER	DOUILLE	CASQUILLO
1b	4	2	682 018 470		LAGER	17x40x12 6203 RS	BEARING	ROULEMENT	CUSCINETTO
1b	5	6	680 147 490		SCHRAUBE	M 6x20 UNI 5739	SCREW	VIS	TORNILLO
1b	6	14	680 144 370		SCHEIBE	M 6x18 UNI 6593	WASHER	RONDELLE	ARANDELA
1b	7	6	680 145 990		SCHRAUBE	3,9x19 UNI 6954	SCREW	VIS	TORNILLO
1b	8	2	680 140 080		SCHRAUBE	4,0x25 UNI 9708	SCREW	VIS	TORNILLO
1b	9	2	682 022 180		GRIFF		KNOB	POIGNÉE	ASA
1b	10	2	680 456 760		ZWISCHENSTÜCK		CLAMP	PIÈCE INTERMÉDIAIRE	PIEZA INTERMEDIA
1b	11	17	920 406 000		SECHSKANTMUTTE R	M6	HEX NUT	ECROU HEXAGONAL	TUERCA HEXAGONAL
1b	12	2	680 456 750		KLEMME		CLAMP	PINCE	BORNE
1b	13	2	682 025 880		TREIBRAD		PULLEY	POULIE RÉCEPTRICE	POLEA
1b	14	1	680 243 570		KEILRIEMEN	XZ-21	BELT	COURROIE	CORREA
1b	15	3	680 144 480		SCHEIBE	M 8x24 UNI 6593	WASHER	RONDELLE	ARANDELA
1b	16	5	680 109 540		SCHRAUBE	M 8x16 UNI 5739	SCREW	VIS	TORNILLO
1b	17	2	684 018 460		ABSTANDHALTER		SPACER	ECARTEUR	SEPARADOR
1b	18	1	682 018 440		MESSERWELLE		BLADE HOLDER SHAFT	PORTE-LAME	ÁRBOL DE CUCHILLAS
1b	19	15	682 018 430		MESSER		BLADE	LAME	CUCHILLAS
1b	20	14	684 018 450		ABSTANDSBUCHSE		SPACER BUSH	DOUILLE D'ÉCARTEMENT	CASQUILLO SEPARACIÓN
1b	21	2	680 100 000		SCHRAUBE	TE M 6X50 UNI 5737	SCREW	VIS	TORNILLO
1b	22	2	680 144 750		SCHEIBE	M6 UNI 6592	WASHER	RONDELLE	ARANDELA
1b	23	2	680 142 000		MUTTER	M 6 UNI 5588	NUT	ECROU	TUERCA
1b	24	1	683 018 350		STANGE		BAR	TRINGLE	BARRA
1b	25	1	682 024 530		HUTMUTTER	M 6	CAP NUT	ECROU BORGNE	TUERCA DE SOMBRETERE
1b	26	2	920 406 000		SECHSKANTMUTTE R	M6	HEX NUT	ECROU HEXAGONAL	TUERCA HEXAGONAL
1b	27	2	682 022 260		KLEMM-MUTTER	M 6	CLAMPING NUT	ECROU DE CALAGE	TUERCA DE APRIETE
1b	28	2	680 142 360		FÄCHERSCHEIBE	M 6 DIN 6798	WASHER	RONDELLE	ARANDELA
1b	29	1	682 019 080		FEDER		SPRING	RESSORT	MUELLE
1b	30	2	682 024 080		STELLRAD		ADJUSTMENT WHEEL	ROUE DE RÉGLAGE	RUEDA DE AJUSTE
1b	31	1	683 022 290		STANGE		BAR	TRINGLE	BARRA
1b	32	8	680 142 760		SCHRAUBE	M 6x16 UNI 5739	SCREW	VIS	TORNILLO
1b	33	4	684 018 330		ACHSLAGER		AXLE BEARING	PALIER	COJINETE DEL EJE
1b	34	2	683 018 310		ACHSE		AXLE	ESSIEU AVANT	EJE
1b	35	4	680 145 250		FEDERSCHEIBE		SPRING WASHER	RONDELLE A RESSORT	ARANDELA ELASTICO
1b	36	8	680 245 240		SICHERUNGSRING	13x19x1 DIN 988	CIRCLIP	ANNEAU D'ÉTANCHÉITÉ	CIRCLIP
1b	37	8	680 203 680		LAGER	12x26x12,4	BEARING	ROULEMENT	COJINETE
1b	38	4	683 006 790		RAD	Ø=200/26	WHEEL	ROUE	RUEDA
1b	39	18	680 144 460		SCHEIBE	M 8 UNI 6592	WASHER	RONDELLE	ARANDELA
1b	40	6	680 142 030		MUTTER	M 8 UNI 5588	NUT	ECROU	TUERCA
1b	41	4	680 023 500		RADKAPPE, SCHWARZ	Ø=200 RAL102	WHEEL COVER, BLACK	CHAPEAU DE MOYEU, NOIR	CAPERUZA DE RUEDA, NEGRO
1b	42	1	680 035 500		RIEMENABDECKUNG , SCHWARZ		BELT COVER, BLACK	COUVERCLE DE COURROIE, NOIR	CUBIERTA DE CORREA, NEGRO
1b	43	2	681 017 300		SCHRAUBE		SCREW	VIS	TORNILLO
1b	44	10	680 144 450		MUTTER	M 8 DIN 985 (B&S 3,5)	NUT	ECROU	TUERCA
1b	45	6	680 152 560		SCHRAUBE	M 8x20 UNI 5739	SCREW	VIS	TORNILLO
1b	46	1	682 021 910		STANGE GRASKLAPPE		GRASS FLAP ROD	TRINGLE TRAPPE À HERBE	BARRA TAPA DE YERBA
1b	47	2	680 145 900		SICHERUNGSSCHEI BE	D=7	LOCK WASHER	RONDELLE D'ARRÊT	ARANDELA DE SEGURIDAD

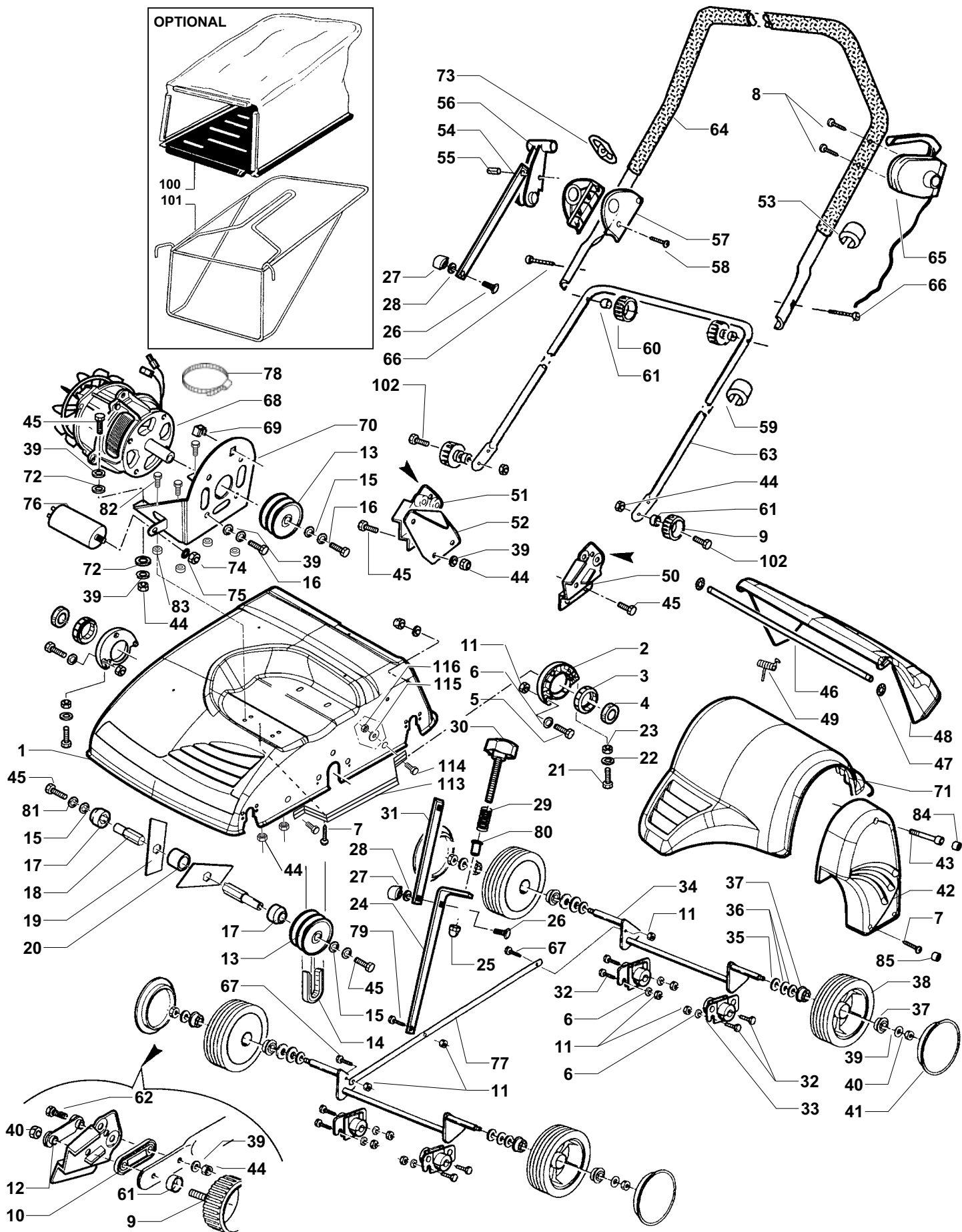

Seite / Page	Pos.	UV380	Teil-Nr. Part No. No. de pièce No. de pieza	Hinweise Notes Renseign. Nota	Bezeichnung	Spezifikation Specification	Description	Désignation	Denominación
1b	48	1	684 018 300		GRASKLAPPE		GRASS FLAP	TRAPPE À HERBE	TAPA PARA YERBA
1b	49	1	682 019 770		FEDER		SPRING	RESSORT	MUELLE
1b	50	1	683 008 010		GRIFFTRÄGER LINKS		LEFT HANDLE SUPPORT	SUPPORT DE POIGNÉE GAUCHE	SOPORTE DE ASA IZQUIERDO
1b	51	1	683 008 000		GRIFFTRÄGER RECHTS		RIGHT HANDLE SUPPORT	SUPPORT DE POIGNÉE DROITE	SOPORTE DE ASA DERECHO
1b	52	1	683 018 380		GRUNDPLATTE		SUPPORT	PLAQUE D'ASSISE	BASE
1b	53	1	680 446 340		KABELCLIPP		CABLE CLIP	CLIP DE CÂBLE	CLIP PARA CABLE
1b	54	1	683 018 360		STANGE		BAR	TRINGLE	BARRA
1b	55	1	681 021 900		STIFT		PIN	CHEVILLE	PASADOR
1b	56	1	684 018 390		HEBEL		LEVER	LEVIER	PALANCA
1b	57	2	684 018 400		HEBELTRÄGER		LEVER SUPPORT	SUPPORT DE LEVIER	SOPORTE DE PALANCA
1b	58	4	681 022 110		SCHRAUBE	3,9x25	SCREW	VIS	TORNILLO
1b	59	1	680 446 330		KABELCLIPP		CABLE CLIP	CLIP DE CÂBLE	CLIP PARA CABLE
1b	60	2	682 008 490		KLEMMMUTTER	M 8	CLAMPING NUT	ECROU DE CALAGE	TUERCA DE APRIETE
1b	61	4	680 340 060		SCHEIBE		WASHER	RONDELLE	ARANDELA
1b	62	2	680 184 540		SCHRAUBE	M 8x30 UNI 5739	SCREW	VIS	TORNILLO
1b	63	1	683 018 410		UNTERHOLM		LOWER HANDLE	MANCHE INFÉRIEURE	MANGO INFERIOR
1b	64	1	683 021 960		OBERHOLM		UPPER HANDLE	MANCHE SUPÉRIEURE	MANGO SUPERIOR
1b	65	1	682 022 160		SCHALTER		SWITCH	COMMUTATEUR	INTERRUPTOR
1b	66	2	680 101 740		SCHRAUBE	M 8x55	SCREW	VIS	TORNILLO
1b	67	2	681 024 440		SCHRAUBE	M 6x20 UNI 5933	SCREW	VIS	TORNILLO
1b	68	1	680 028 770		MOTOR	1800W S6 S/F ARIEG	ENGINE	MOTEUR	MOTOR
1b	69	1	682 016 350		KLAMMER		CLAMP	BRIDE DE FIXATION	GRAPA
1b	70	1	680 035 480		MOTORTRÄGER KPL.		MOTOR BRACKET, CPL.	SUPPORT DE MOTEUR CPL.	SOPORTE DE MOTOR CPL.
1b	71	1	680 069 340		MOTORABDECKUNG		MOTOR COVER	COUVERCLE MOTEUR	CUBIERTA DEL MOTOR
1b	72	4	680 035 590		KUNSTSTOFFSCHEI BE	D=11,6x24,6	PLASTIC WASHER	RONDELLE	ARANDELA
1b	73	1	680 409 570		ZUGENTLASTUNG KABEL		STRAIN RELIEF CABLE	DÉCONTRACTION CÂBLE	CABLE DESCARGA DE TRACCIÓN
1b	74	1	680 146 410		MUTTER	M 8 UNI 5589	NUT	ECROU	TUERCA
1b	75	1	680 145 480		SCHEIBE	M 8 DIN 6798	WASHER	RONDELLE	ARANDELA
1b	76	1	680 247 600		KONDENSATOR	16µF	CAPACITOR	CONDENSATEUR	CONDENSADOR
1b	77	1	683 024 310		TRAVERSE		CROSSBAR	TRAVERSE	TRAVIESA
1b	78	1	682 017 440		KABELBINDER		CLIP	BRIDE DE FIXATION	ABRAZADERA
1b	79	1	681 024 450		SCHRAUBE	M 6x18 UNI 5739	SCREW	VIS	TORNILLO
1b	80	1	682 025 460		BUCHSE		BUSH	DOUILLE	CASQUILLO
1b	81	7	680 145 480		SCHEIBE	M 8 DIN 6798	WASHER	RONDELLE	ARANDELA
1b	82	4	680 140 510		SCHRAUBE	TE M 8x25 UNI 5739 8	SCREW	VIS	TORNILLO
1b	83	4	680 035 580		ISOLIERELEMENT		INSERT INSULATING MOTOR SCREWS	ÉLÉMENT D'ISOLATION	ELEMENTO AISLANTE
1b	84	1	680 035 600		ISOLIERKAPPE	D=14,5	INSULATING CAP	CHAPE D'ISOLATION	CUBIERTO DE AISLADOR
1b	85	2	680 035 610		ISOLIERKAPPE	D=9,5	INSULATING CAP	CHAPE D'ISOLATION	CUBIERTO DE AISLADOR
1b	100	1	682 043 100		GRASSACK	MAKITA	GRASS BAG	SAC À HERBE	SACO PARA YERBA
1b	101	1	683 018 550		RAHMEN		FRAME	CADRE	MARCO
1b	102	2	680 172 960		SCHRAUBE	M8x35 UNI 5739	H.H. SCREW	VIS	TORNILLO
1b	113	2	680 075 300		SEITENSCHUTZ		SIDE PROTECTION	PROTECTION	PROTECTOR
1b	114	4	680 147 470		SCHRAUBE	TE M 5x14 UNI 5739 4	SCREW	VIS	TORNILLO
1b	115	4	680 147 740		SCHEIBE	M 5X15 UNI 659	BOLT WASHER	RONDELLE	ARANDELA
1b	116	4	680 140 270		SICHERUNGSMUTTE R		SELF-LOCKING NUT	ECROU DE SÉCURITÉ	TUERCA DE PROTEC.

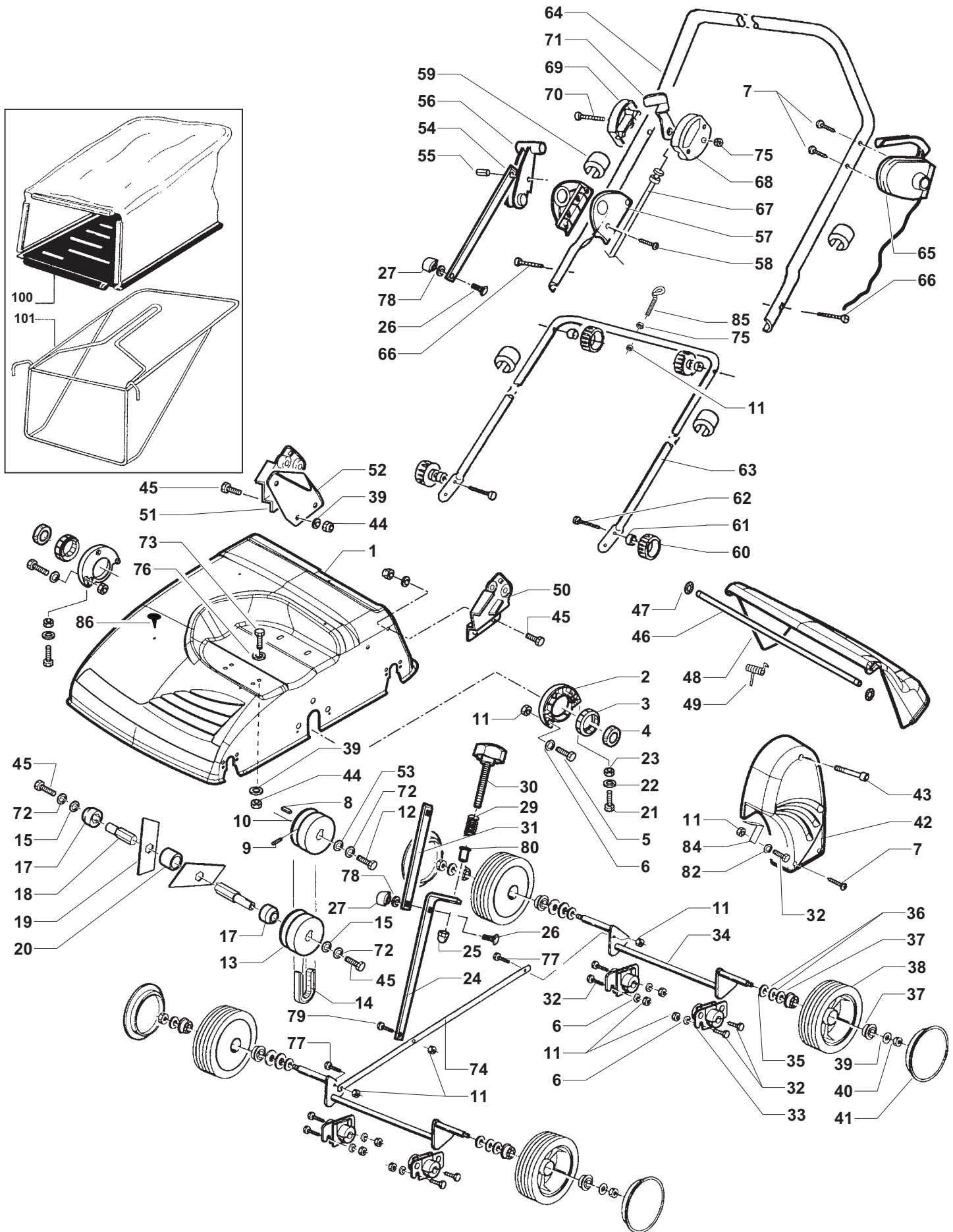

Seite / Page	Pos.	EUV400	Teil-Nr. Part No. No. de pièce No. de pieza	Hinweise Notes Renseign. Nota	Bezeichnung	Spezifikation Specification	Description	Désignation	Denominación
2a	1	1	683 043 090		HAUBE, BLAU		DECK, BLUE	CAPOT, BLEU	CAPOTA, AZUL
2a	2	2	684 018 490		LAGERGEHÄUSE		BUSHING	LOGEMENT	SOPORTE
2a	3	2	684 018 480		LAGERBUCHSE		BEARING HOLDER	DOUILLE	CASQUILLO
2a	4	2	682 018 470		LAGER	17x40x12 6203 RS	BEARING	ROULEMENT	CUSCINETTO
2a	5	6	680 147 490		SCHRAUBE	M 6x20 UNI 5739	SCREW	VIS	TORNILLO
2a	6	14	680 144 370		SCHEIBE	M 6x18 UNI 6593	WASHER	RONDELLE	ARANDELA
2a	7	4	680 145 990		SCHRAUBE	3,9x19 UNI 6954	SCREW	VIS	TORNILLO
2a	8	1	682 021 950		PASSFEDER	3/16"x3/16"x1 1/2"	FEATHER KEY	RESSORT D'AJUSTAGE	CHAVETA
2a	9	1	681 022 080		GEWINDESTIFT	M 6x10 UNI 5927	SETSCREW	VIS SANS TÊTE	PASADOR ROSCADO
2a	10	1	682 025 860		TREIBRAD		PULLEY	POULIE RÉCEPTRICE	POLEA
2a	11	17	920 406 000		SECHSKANTMUTTER	M6	HEX NUT	ECROU HEXAGONAL	TUERCA HEXAGONAL
2a	12	1	681 022 100		SCHRAUBE	1/4x5/8" (B&S 3,5)	SCREW	VIS	TORNILLO
2a	13	1	682 025 870		TREIBRAD		PULLEY	POULIE RÉCEPTRICE	POLEA
2a	14	1	682 025 830		KEILRIEMEN	XPZ 637	BELT	COURROIE	CORREA
2a	15	2	680 144 480		SCHEIBE	M 8x24 UNI 6593	WASHER	RONDELLE	ARANDELA
2a	17	2	684 018 460		ABSTANDHALTER		SPACER	ECARTEUR	SEPARADOR
2a	18	1	682 018 440		MESSERWELLE		BLADE HOLDER SHAFT	PORTE-LAME	ÁRBOL DE CUCHILLAS
2a	19	15	682 018 430		MESSER		BLADE	LAME	CUCHILLAS
2a	20	14	684 018 450		ABSTANDSBUCHSE		SPACER BUSH	DOUILLE D'ÉCARTEMENT	CASQUILLO SEPARACIÓN
2a	21	2	680 145 960		SCHRAUBE	M 6x45 UNI 5739	SCREW	VIS	TORNILLO
2a	22	2	680 170 520		SCHEIBE	M 6 UNI 6592	WASHER	RONDELLE	ARANDELA
2a	23	2	680 142 000		MUTTER	M 6 UNI 5588	NUT	ECROU	TUERCA
2a	24	1	683 018 350		STANGE		BAR	TRINGLE	BARRA
2a	25	1	682 024 530		HUTMUTTER	M 6	CAP NUT	ECROU BORGNE	TUERCA DE SOMBRETERE
2a	26	2	681 022 210		SCHRAUBE	M 6x16	SCREW	VIS	TORNILLO
2a	27	2	682 022 260		KLEMM-MUTTER	M 6	CLAMPING NUT	ECROU DE CALAGE	TUERCA DE APRIETE
2a	29	1	682 019 080		FEDER		SPRING	RESSORT	MUELLE
2a	30	1	682 024 080		STELLRAD		ADJUSTMENT WHEEL	ROUE DE RÉGLAGE	RUEDA DE AJUSTE
2a	31	1	683 022 290		STANGE		BAR	TRINGLE	BARRA
2a	32	8	680 142 760		SCHRAUBE	M 6x16 UNI 5739	SCREW	VIS	TORNILLO
2a	33	4	684 018 330		ACHSLAGER		AXLE BEARING	PALIER	COJINETE DEL EJE
2a	34	2	683 018 310		ACHSE		AXLE	ESSIEU AVANT	EJE
2a	35	4	680 145 250		FEDERSCHEIBE		SPRING WASHER	RONDELLE A RESSORT	ARANDELA ELASTICO
2a	36	8	680 245 240		SICHERUNGSRING	13x19x1 DIN 988	CIRCLIP	ANNEAU D'ÉTANCHÉITÉ	CIRCLIP
2a	37	8	680 203 680		LAGER	12x26x12,4	BEARING	ROULEMENT	COJINETE
2a	38	4	683 006 790		RAD	Ø=200/26	WHEEL	ROUE	RUEDA
2a	39	12	680 144 460		SCHEIBE	M 8 UNI 6592	WASHER	RONDELLE	ARANDELA
2a	40	4	680 142 030		MUTTER	M 8 UNI 5588	NUT	ECROU	TUERCA
2a	41	4	684 023 370		RADKAPPE, SCHWARZ		WHEEL COVER, BLACK	CHAPEAU DE MOYEU, NOIR	CAPERUZA DE RUEDA, NEGRO
2a	42	1	684 022 450		RIEMENABDECKUNG, SCHWARZ		BELT COVER, BLACK	COUVERCLE DE COURROIE, NOIR	CUBIERTA DE CORREA, NEGRO
2a	43	1	681 017 300		SCHRAUBE		SCREW	VIS	TORNILLO
2a	44	8	680 144 450		MUTTER	M 8 DIN 985 (B&S 3,5)	NUT	ECROU	TUERCA
2a	45	4	680 152 560		SCHRAUBE	M 8x20 UNI 5739	SCREW	VIS	TORNILLO
2a	46	1	682 021 910		STANGE GRASKLAPPE		GRASS FLAP ROD	TRINGLE TRAPPE À HERBE	BARRA TAPA DE YERBA
2a	47	2	680 145 900		SICHERUNGSSCHEIBE	D=7	LOCK WASHER	RONDELLE D'ARRÊT	ARANDELA DE SEGURIDAD
2a	48	1	684 018 300		GRASKLAPPE		GRASS FLAP	TRAPPE À HERBE	TAPA PARA YERBA
2a	49	1	682 019 770		FEDER		SPRING	RESSORT	MUELLE
2a	50	1	683 008 010		GRIFFTRÄGER LINKS		LEFT HANDLE SUPPORT	SUPPORT DE POIGNÉE GAUCHE	SOPORTE DE ASA IZQUIERDO
2a	51	1	683 008 000		GRIFFTRÄGER RECHTS		RIGHT HANDLE SUPPORT	SUPPORT DE POIGNÉE DROITE	SOPORTE DE ASA DERECHO

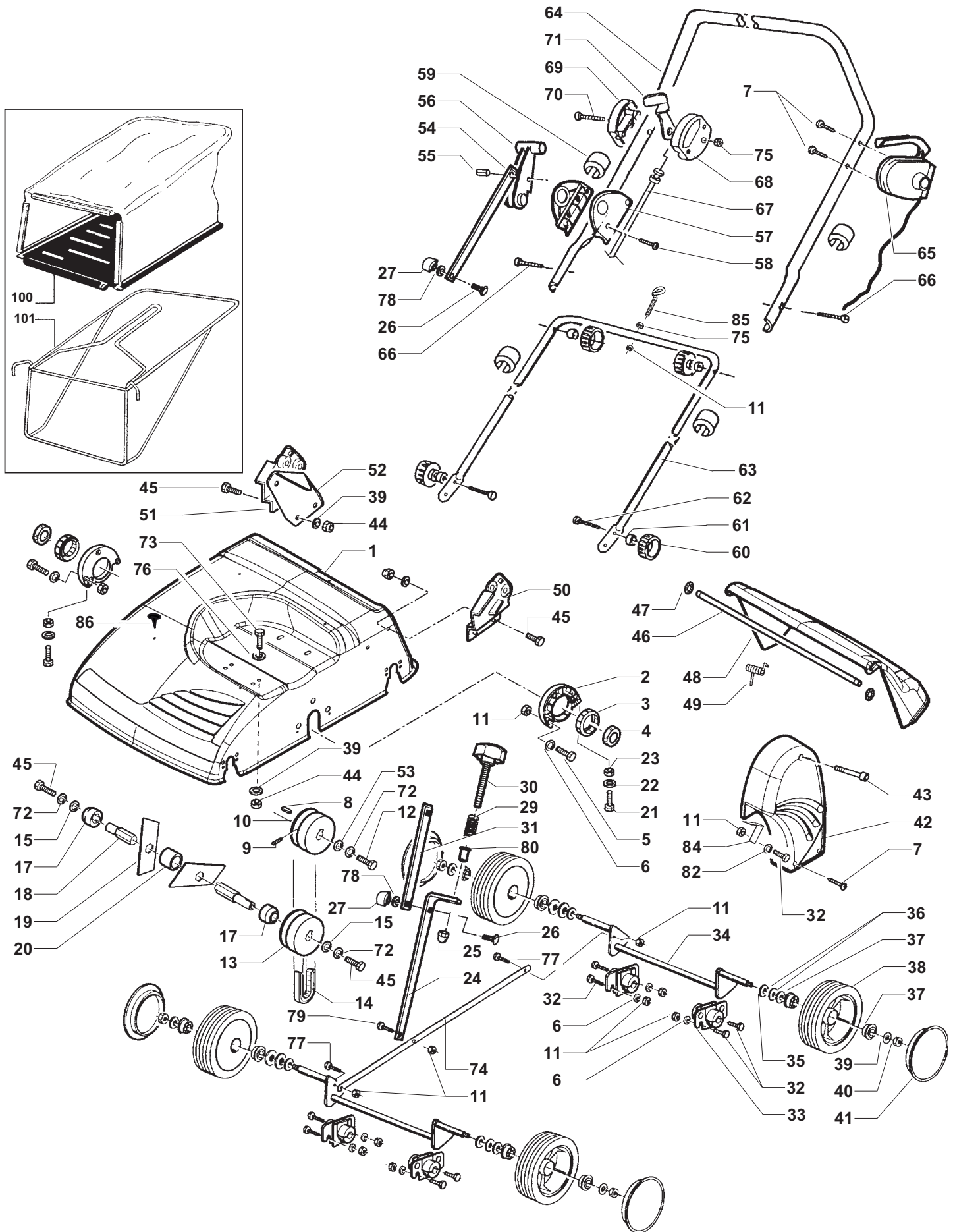

Seite / Page	Pos.	Teil-Nr. Part No. No. de pièce No. de pieza	Hinweise Notes Renseign. Nota	Bezeichnung	Spezifikation Specification	Description	Désignation	Denominación
2a	52	1 683 018 380		GRUNDPLATTE		SUPPORT	PLAQUE D'ASSISE	BASE
2a	53	1 680 147 760		SCHEIBE	M 6x24 UNI 6593 (B&S 3,5)	WASHER	RONDELLE	ARANDELA
2a	54	1 683 018 360		STANGE		BAR	TRINGLE	BARRA
2a	55	1 681 021 900		STIFT		PIN	CHEVILLE	PASADOR
2a	56	1 684 018 390		HEBEL		LEVER	LEVIER	PALANCA
2a	57	2 684 018 400		HEBELTRÄGER		LEVER SUPPORT	SUPPORT DE LEVIER	SOPORTE DE PALANCA
2a	58	4 681 022 110		SCHRAUBE	3,9x25	SCREW	VIS	TORNILLO
2a	59	4 680 446 330		KABELCLIPP		CABLE CLIP	CLIP DE CÂBLE	CLIP PARA CABLE
2a	60	4 682 008 490		KLEMMMUTTER	M 8	CLAMPING NUT	ECROU DE CALAGE	TUERCA DE APRIETE
2a	61	4 680 340 060		SCHEIBE		WASHER	RONDELLE	ARANDELA
2a	62	2 681 022 230		SCHRAUBE	M 8x32,5	SCREW	VIS	TORNILLO
2a	63	1 683 018 410		UNTERHOLM		LOWER HANDLE	MANCHE INFÉRIEURE	MANGO INFERIOR
2a	64	1 683 018 420		OBERHOLM		UPPER HANDLE	MANCHE SUPÉRIEURE	MANGO SUPERIOR
2a	65	1 682 021 980		SCHALTER	(B&S 3,5)	SWITCH	COMMUTATEUR	INTERRUPTOR
2a	66	2 680 101 740		SCHRAUBE	M 8x55	SCREW	VIS	TORNILLO
2a	67	1 682 021 990		BOWDENZUG	(B&S 3,5)	BOWDEN WIRE	CÂBLE SOUS GAINÉ	TRANSMISION BOWDEN
2a	68	1 680 446 320		GEHÄUSE INNEN		HOUSING INTERIOR	CARTER INTÉRIEUR	CARCASA INTERIOR
2a	69	1 680 446 310		GEHÄUSE AUSSEN		HOUSING EXTERIOR	CARTER EXTÉRIEUR	CARCASA EXTERIOR
2a	70	1 680 140 310		SCHRAUBE	M 5x35 UNI 7687	SCREW	VIS	TORNILLO
2a	71	1 680 479 770		GASHEBEL		THROTTLE	ACCÉLÉRATEUR	PALANCA DEL ACELERADOR
2a	72	1 680 144 450		MUTTER	M 8 DIN 985 (B&S 3,5)	NUT	ECROU	TUERCA
2a	73	4 680 142 020		SCHRAUBE	M 8x40 UNI 5737	SCREW	VIS	TORNILLO
2a	74	1 683 024 310		TRAVERSE		CROSSBAR	TRAVERSE	TRAVIESA
2a	75	1 680 140 300		MUTTER	M 5 UNI 5588	NUT	ECROU	TUERCA
2a	76	4 680 442 060		SCHEIBE		WASHER	RONDELLE	ARANDELA
2a	77	2 681 024 440		SCHRAUBE	M 6x20 UNI 5933	SCREW	VIS	TORNILLO
2a	78	2 680 142 360		FÄCHERSCHEIBE	M 6 DIN 6798	WASHER	RONDELLE	ARANDELA
2a	79	1 681 024 450		SCHRAUBE	M 6x18 UNI 5739	SCREW	VIS	TORNILLO
2a	80	1 682 025 460		BUCHSE		BUSH	DOUILLE	CASQUILLO
2a	82	1 680 144 750		SCHEIBE	M6 UNI 6592	WASHER	RONDELLE	ARANDELA
2a	84	1 680 031 510		KLEMME		CLAMP	PINCE	PINZA
2a	85	1 680 295 640		HALTER FÜR STARTERSEIL		STARTER ROPE HOLDER	SUPPORT	SOPORTE
2a	86	3 680 070 230		STOPFEN	D=8 5753AA	PLUG	BOUCHON	TAPON
2a	100	1 682 043 100		GRASSACK	MAKITA	GRASS BAG	SAC À HERBE	SACO PARA YERBA
2a	101	1 683 018 550		RAHMEN		FRAME	CADRE	MARCO

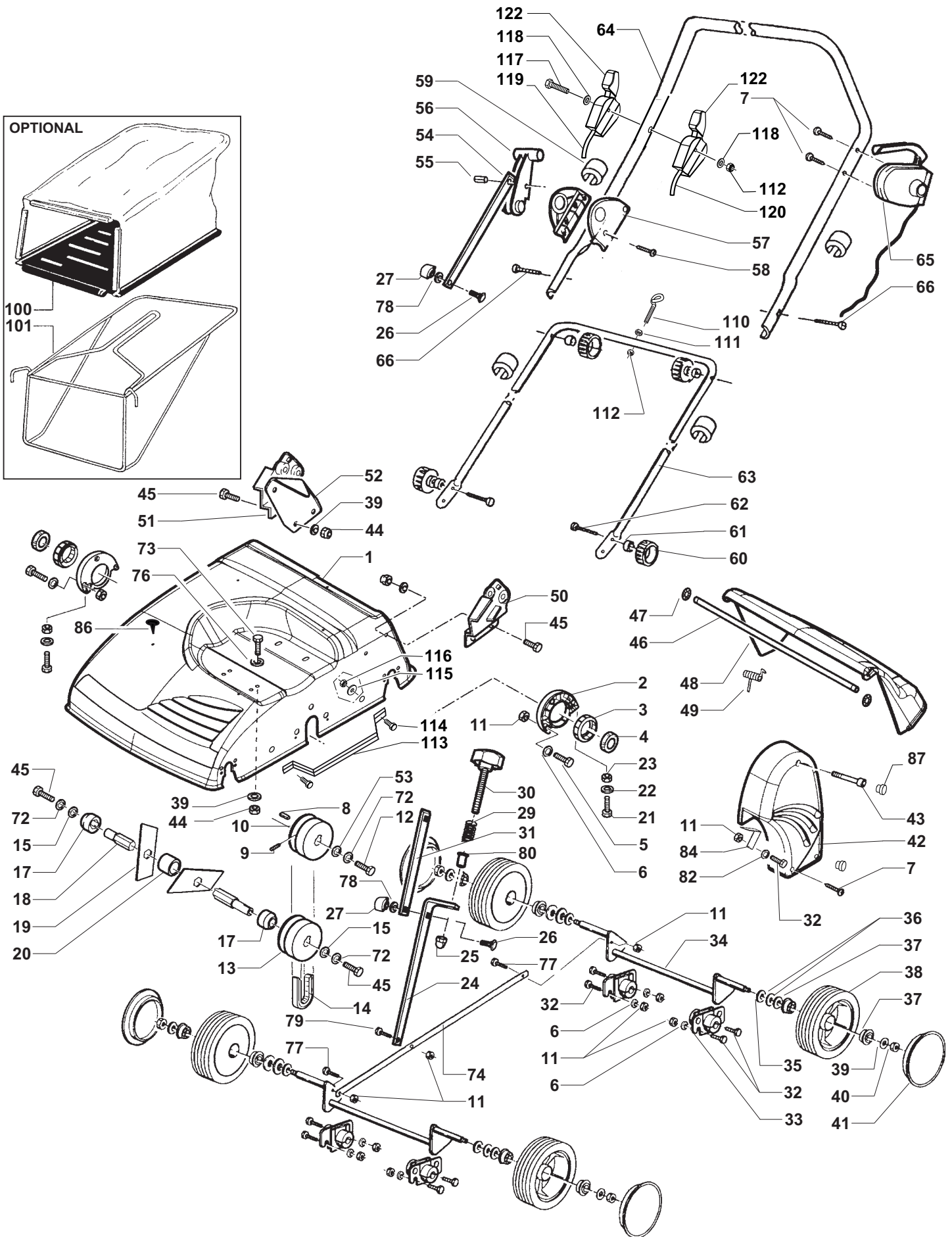
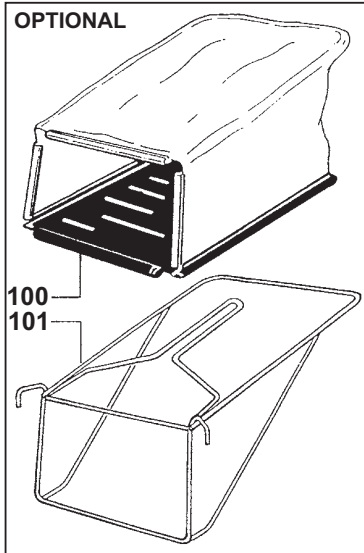

Seite / Page	Pos.	Teil-Nr. Part No. No. de pièce No. de pieza	Hinweise Notes Renseign. Nota	Bezeichnung	Spezifikation Specification	Description	Désignation	Denominación
2b	1	1 683 043 090		HAUBE, BLAU		DECK, BLUE	CAPOT, BLEU	CAPOTA, AZUL
2b	2	2 684 018 490		LAGERGEHÄUSE		BUSHING	LOGEMENT	SOPORTE
2b	3	2 684 018 480		LAGERBUCHSE		BEARING HOLDER	DOUILLE	CASQUILLO
2b	4	2 682 018 470		LAGER	17x40x12 6203 RS	BEARING	ROULEMENT	CUSCINETTO
2b	5	6 680 147 490		SCHRAUBE	M 6x20 UNI 5739	SCREW	VIS	TORNILLO
2b	6	14 680 144 370		SCHEIBE	M 6x18 UNI 6593	WASHER	RONDELLE	ARANDELA
2b	7	4 680 145 990		SCHRAUBE	3,9x19 UNI 6954	SCREW	VIS	TORNILLO
2b	8	1 682 021 950		PASSFEDER	3/16"x3/16"x1 1/2"	FEATHER KEY	RESSORT D'AJUSTAGE	CHAVETA
2b	9	1 680 037 150		GEWINDESTIFT	M 6x10	GRUB SCREW	VIS SANS TÊTE	PASADOR ROSCADO
2b	10	1 682 025 860		TREIBRAD		PULLEY	POULIE RÉCEPTRICE	POLEA
2b	11	20 920 406 000		SECHSKANTMUTTER	M6	HEX NUT	ECROU HEXAGONAL	TUERCA HEXAGONAL
2b	12	1 680 022 390		SCHRAUBE	TE UNF 5/16x5/8"	SCREW	VIS	TORNILLO
2b	13	1 682 025 870		TREIBRAD		PULLEY	POULIE RÉCEPTRICE	POLEA
2b	14	1 682 025 830		KEILRIEMEN	XPZ 637	BELT	COURROIE	CORREA
2b	15	2 680 035 910		SCHEIBE	8.5x22x2	PLANE WASHER	RONDELLE	ARANDELA
2b	17	2 684 018 460		ABSTANDHALTER		SPACER	ECARTEUR	SEPARADOR
2b	18	1 682 018 440		MESSERWELLE		BLADE HOLDER SHAFT	PORTE-LAME	ÁRBOL DE CUCHILLAS
2b	19	15 682 018 430		MESSER		BLADE	LAME	CUCHILLAS
2b	20	14 684 018 450		ABSTANDBUCHSE		SPACER BUSH	DOUILLE D'ÉCARTEMENT	CASQUILLO SEPARACIÓN
2b	21	2 680 100 000		SCHRAUBE	TE M 6X50 UNI 5737	SCREW	VIS	TORNILLO
2b	22	2 680 144 750		SCHEIBE	M6 UNI 6592	WASHER	RONDELLE	ARANDELA
2b	23	2 680 142 000		MUTTER	M 6 UNI 5588	NUT	ECROU	TUERCA
2b	24	1 683 018 350		STANGE		BAR	TRINGLE	BARRA
2b	25	1 682 024 530		HUTMUTTER	M 6	CAP NUT	ECROU BORGNE	TUERCA DE SOMBRETERE
2b	26	2 681 022 210		SCHRAUBE	M 6x16	SCREW	VIS	TORNILLO
2b	27	2 682 022 260		KLEMM-MUTTER	M 6	CLAMPING NUT	ECROU DE CALAGE	TUERCA DE APRIETE
2b	29	1 682 019 080		FEDER		SPRING	RESSORT	MUELLE
2b	30	1 682 024 080		STELLRAD		ADJUSTMENT WHEEL	ROUE DE RÉGLAGE	RUEDA DE AJUSTE
2b	31	1 683 022 290		STANGE		BAR	TRINGLE	BARRA
2b	32	9 680 142 760		SCHRAUBE	M 6x16 UNI 5739	SCREW	VIS	TORNILLO
2b	33	4 684 018 330		ACHSLAGER		AXLE BEARING	PALIER	COJINETE DEL EJE
2b	34	2 683 018 310		ACHSE		AXLE	ESSIEU AVANT	EJE
2b	35	4 680 145 250		FEDERSCHEIBE		SPRING WASHER	RONDELLE A RESSORT	ARANDELA ELASTICO
2b	36	12 680 245 240		SICHERUNGSRING	13x19x1 DIN 988	CIRCLIP	ANNEAU D'ÉTANCHÉITÉ	CIRCLIP
2b	37	8 680 203 680		LAGER	12x26x12,4	BEARING	ROULEMENT	COJINETE
2b	38	4 683 006 790		RAD	Ø=200/26	WHEEL	ROUE	RUEDA
2b	39	12 680 144 460		SCHEIBE	M 8 UNI 6592	WASHER	RONDELLE	ARANDELA
2b	40	4 680 142 030		MUTTER	M 8 UNI 5588	NUT	ECROU	TUERCA
2b	41	4 684 023 370		RADKAPPE, SCHWARZ		WHEEL COVER, BLACK	CHAPEAU DE MOYEU, NOIR	CAPERUZA DE RUEDA, NEGRO
2b	42	1 680 035 500		RIEMENABDECKUNG, SCHWARZ		BELT COVER, BLACK	COUVERCLE DE COURROIE, NOIR	CUBIERTA DE CORREA, NEGRO
2b	43	1 681 017 300		SCHRAUBE		SCREW	VIS	TORNILLO
2b	44	8 680 144 450		MUTTER	M 8 DIN 985 (B&S 3,5)	NUT	ECROU	TUERCA
2b	45	6 680 152 560		SCHRAUBE	M 8x20 UNI 5739	SCREW	VIS	TORNILLO
2b	46	1 682 021 910		STANGE GRASKLAPPE		GRASS FLAP ROD	TRINGLE TRAPPE À HERBE	BARRA TAPA DE YERBA
2b	47	2 680 145 900		SICHERUNGSSCHEIBE	D=7	LOCK WASHER	RONDELLE D'ARRÊT	ARANDELA DE SEGURIDAD
2b	48	1 684 018 300		GRASKLAPPE		GRASS FLAP	TRAPPE À HERBE	TAPA PARA YERBA
2b	49	1 682 019 770		FEDER		SPRING	RESSORT	MUELLE
2b	50	1 683 008 010		GRIFFTRÄGER LINKS		LEFT HANDLE SUPPORT	SUPPORT DE POIGNÉE GAUCHE	SOPORTE DE ASA IZQUIERDO

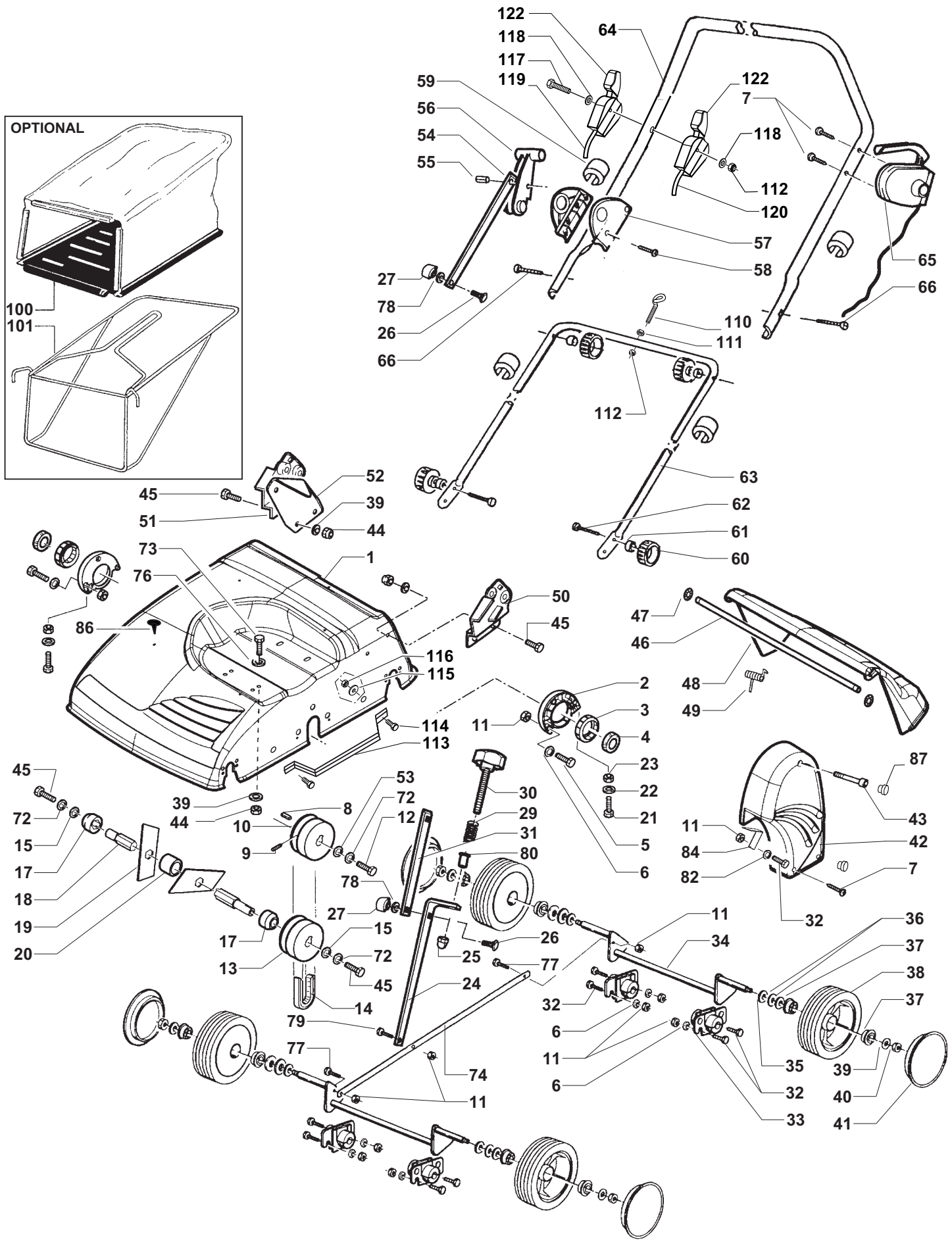

Seite / Page	Pos.	EUV400	Teil-Nr. Part No. No. de pièce No. de pieza	Hinweise Notes Renseign. Nota	Bezeichnung	Spezifikation Specification	Description	Désignation	Denominación
2b	51	1	683 008 000		GRIFFRÄGER RECHTS		RIGHT HANDLE SUPPORT	SUPPORT DE POIGNÉE DROITE	SOPORTE DE ASA DERECHO
2b	52	1	683 018 380		GRUNDPLATTE		SUPPORT	PLAQUE D'ASSISE	BASE
2b	53	1	680 147 760		SCHEIBE	M 6x24 UNI 6593 (B&S 3,5)	WASHER	RONDELLE	ARANDELA
2b	54	1	683 018 360		STANGE		BAR	TRINGLE	BARRA
2b	55	1	681 021 900		STIFT		PIN	CHEVILLE	PASADOR
2b	56	1	684 018 390		HEBEL		LEVER	LEVIER	PALANCA
2b	57	2	684 018 400		HEBELTRÄGER		LEVER SUPPORT	SUPPORT DE LEVIER	SOPORTE DE PALANCA
2b	58	4	681 022 110		SCHRAUBE	3,9x25	SCREW	VIS	TORNILLO
2b	59	4	680 446 330		KABELCLIPP		CABLE CLIP	CLIP DE CÂBLE	CLIP PARA CABLE
2b	60	4	682 008 490		KLEMMMUTTER	M 8	CLAMPING NUT	ECROU DE CALAGE	TUERCA DE APRIETE
2b	61	4	680 340 060		SCHEIBE		WASHER	RONDELLE	ARANDELA
2b	62	2	681 022 230		SCHRAUBE	M 8x32,5	SCREW	VIS	TORNILLO
2b	63	1	680 052 640		UNTERHOLM		LOWER HANDLE	MANCHE INFÉRIEURE	MANGO INFERIOR
2b	64	1	683 018 420		OBERHOLM		UPPER HANDLE	MANCHE SUPÉRIEURE	MANGO SUPERIOR
2b	65	1	680 038 080		SCHALTER	(B&S 3,5)	SWITCH	COMMUTATEUR	INTERRUPTOR
2b	66	2	680 101 740		SCHRAUBE	M 8x55	SCREW	VIS	TORNILLO
2b	72	2	680 145 480		SCHEIBE	M 8 DIN 6798	WASHER	RONDELLE	ARANDELA
2b	73	4	680 142 020		SCHRAUBE	M 8x40 UNI 5737	SCREW	VIS	TORNILLO
2b	74	1	683 024 310		TRAVERSE		CROSSBAR	TRAVERSE	TRAVIESA
2b	76	4	680 442 060		SCHEIBE		WASHER	RONDELLE	ARANDELA
2b	77	2	681 024 440		SCHRAUBE	M 6x20 UNI 5933	SCREW	VIS	TORNILLO
2b	78	3	680 142 360		FÄCHERSCHEIBE	M 6 DIN 6798	WASHER	RONDELLE	ARANDELA
2b	79	1	681 024 450		SCHRAUBE	M 6x18 UNI 5739	SCREW	VIS	TORNILLO
2b	80	1	682 025 460		BUCHSE		BUSH	DOUILLE	CASQUILLO
2b	82	1	680 144 750		SCHEIBE	M6 UNI 6592	WASHER	RONDELLE	ARANDELA
2b	84	1	680 031 510		KLEMMME		CLAMP	PINCE	PINZA
2b	86	3	680 070 230		STOPFEN	D=8 5753AA	PLUG	BOUCHON	TAPON
2b	87	2	680 037 030		ISOLIERKAPPE		INSULATING CAP	CHAPE D'ISOLATION	CUBIERTO DE AISLADOR
2b	100	1	682 043 100		GRASSACK	MAKITA	GRASS BAG	SAC À HERBE	SACO PARA YERBA
2b	101	1	683 018 550		RAHMEN		FRAME	CADRE	MARCO
2b	110	1	680 295 640		HALTER FÜR STARTERSEIL		STARTER ROPE HOLDER	SUPPORT	SOPORTE
2b	111	1	680 142 000		MUTTER	M 6 UNI 5588	NUT	ECROU	TUERCA
2b	112	2	920 406 000		SECHSKANTMUTTER	M6	HEX NUT	ECROU HEXAGONAL	TUERCA HEXAGONAL
2b	113	2	680 075 300		SEITENSCHUTZ		SIDE PROTECTION	PROTECTION	PROTECTOR
2b	114	4	680 147 470		SCHRAUBE	TE M 5x14 UNI 5739 4	SCREW	VIS	TORNILLO
2b	115	4	680 147 740		SCHEIBE	M 5X15 UNI 659	BOLT WASHER	RONDELLE	ARANDELA
2b	116	4	680 140 270		SICHERUNGSMUTTE R		SELF-LOCKING NUT	ECROU DE SÉCURITÉ	TUERCA DE PROTEC.
2b	117	1	680 194 550		SCHRAUBE	TE M 6x90 UNI 5737	SCREW	VIS	TORNILLO
2b	118	2	680 170 530		SCHEIBE	M 6x18 UNI 65	PLAIN WASHER	RONDELLE	ARANDELA
2b	119	1	680 075 220		BOWDENZUG	CHOKE HONDA	CONTROL CABLE	CÂBLE BOWDEN	TRACCIÓN BOWDEN
2b	120	1	680 075 230		BOWDENZUG	GAS	CONTROL CABLE	CÂBLE BOWDEN	TRACCIÓN BOWDEN
2b	122	2	680 076 720		MOTORFERNBEDIEN UNG		THROTTLE HANDLE	LEVIER	PALANCA

1a UV380 (→2010)
UV380 (→2010)
UV380 (→2010)
UV380 (→2010)

1b UV380 (2011→)
UV380 (2011→)
UV380 (2011→)
UV380 (2011→)

2a EUV400 (→2010)
EUV400 (→2010)
EUV400 (→2010)
EUV400 (→2010)

2b EUV400 (2011→)
EUV400 (2011→)
EUV400 (2011→)
EUV400 (2011→)

	Zeichenerklärung	Key to symbols
=> 1999999 2000000 => 2003.04 => TI 2003/07 Acc. = { m Corr.	Produktion bis Serien-Nr. Neues Teil ab Serien-Nr. Neues Teil ab Jahr / Monat Siehe Technische Information Jahr / Nr. Zubehör (nicht im Lieferumfang) Keine Serienausführung, jedoch verwendbar Beinhaltet Positions-Nr. Meterware Druckfehlerberichtigung	Production to serial number New part from serial number New part from Year / Month See Technical Information Year / No. Accessories (not included in the delivery inventory) No standard execution, may be used Contains item number Sold by the meter Error correction
	Änderungen vorbehalten	Specifications subject to change without notice
	Légende	Explicación de símbolos
=> 1999999 2000000 => 2003.04 => TI 2003/07 Acc. = { m Corr.	Production jusqu'à n° de série Nouveau pièce à partir du n° de série Nouveau pièce à partir de année / mois Voir information technique année / n° Accessoires (non compris dans la livraison) Aucune exécut. en série, cependant utilisable contient n° de numéro Au mètre Rectification d'erreurs	Producción hasta N° de serie Pieza nueva a partir de N° de serie Pieza nueva a partir de año / mes Véase inform. técnico año / N° Accesorios (no incluido en la extensión del suministro) No es de serie, pero sirve Contiene pos N° Por metro Fe de erratas
	Changements sans préavis	Mejoras constructivas sin previo aviso